

**MTS400P**  
**MPEG Test System**  
**Service Manual**



077-0201-00



**MTS400P**  
**MPEG Test System**  
**Service Manual**

Copyright © Tektronix. All rights reserved. Licensed software products are owned by Tektronix or its subsidiaries or suppliers, and are protected by national copyright laws and international treaty provisions.

Tektronix products are covered by U.S. and foreign patents, issued and pending. Information in this publication supersedes that in all previously published material. Specifications and price change privileges reserved.

TEKTRONIX and TEK are registered trademarks of Tektronix, Inc.

## **Contacting Tektronix**

Tektronix, Inc.  
14200 SW Karl Braun Drive  
P.O. Box 500  
Beaverton, OR 97077  
USA

For product information, sales, service, and technical support:

- In North America, call 1-800-833-9200.
- Worldwide, visit [www.tektronix.com](http://www.tektronix.com) to find contacts in your area.

## Warranty

Tektronix warrants that this product will be free from defects in materials and workmanship for a period of one (1) year from the date of shipment. If any such product proves defective during this warranty period, Tektronix, at its option, either will repair the defective product without charge for parts and labor, or will provide a replacement in exchange for the defective product. Parts, modules and replacement products used by Tektronix for warranty work may be new or reconditioned to like new performance. All replaced parts, modules and products become the property of Tektronix.

In order to obtain service under this warranty, Customer must notify Tektronix of the defect before the expiration of the warranty period and make suitable arrangements for the performance of service. Customer shall be responsible for packaging and shipping the defective product to the service center designated by Tektronix, with shipping charges prepaid. Tektronix shall pay for the return of the product to Customer if the shipment is to a location within the country in which the Tektronix service center is located. Customer shall be responsible for paying all shipping charges, duties, taxes, and any other charges for products returned to any other locations.

This warranty shall not apply to any defect, failure or damage caused by improper use or improper or inadequate maintenance and care. Tektronix shall not be obligated to furnish service under this warranty a) to repair damage resulting from attempts by personnel other than Tektronix representatives to install, repair or service the product; b) to repair damage resulting from improper use or connection to incompatible equipment; c) to repair any damage or malfunction caused by the use of non-Tektronix supplies; or d) to service a product that has been modified or integrated with other products when the effect of such modification or integration increases the time or difficulty of servicing the product.

THIS WARRANTY IS GIVEN BY TEKTRONIX WITH RESPECT TO THE PRODUCT IN LIEU OF ANY OTHER WARRANTIES, EXPRESS OR IMPLIED. TEKTRONIX AND ITS VENDORS DISCLAIM ANY IMPLIED WARRANTIES OF MERCHANTABILITY OR FITNESS FOR A PARTICULAR PURPOSE. TEKTRONIX' RESPONSIBILITY TO REPAIR OR REPLACE DEFECTIVE PRODUCTS IS THE SOLE AND EXCLUSIVE REMEDY PROVIDED TO THE CUSTOMER FOR BREACH OF THIS WARRANTY. TEKTRONIX AND ITS VENDORS WILL NOT BE LIABLE FOR ANY INDIRECT, SPECIAL, INCIDENTAL, OR CONSEQUENTIAL DAMAGES IRRESPECTIVE OF WHETHER TEKTRONIX OR THE VENDOR HAS ADVANCE NOTICE OF THE POSSIBILITY OF SUCH DAMAGES.

[W2 – 15AUG04]



---

# Table of Contents

General Safety Summary .....	v
Service Safety Summary.....	vii
Preface .....	ix
Manual Structure.....	ix
Manual Conventions.....	ix
Documentation .....	x

## Introduction

Introduction .....	1-1
Strategy for Servicing .....	1-1
Tektronix Service Offerings .....	1-1
Product Overview .....	1-3

## Theory of Operation

Theory of Operation.....	2-1
A12 Main Board .....	2-1
A20 PCI Backplane Board.....	2-2
Front-Panel Processor Board .....	2-3
Keypad Board.....	2-4
A40 AC Distributor Board.....	2-4
A170 SMPTE310M/ASI/PSI Interface Module.....	2-4
GbE Interface Module (Option IPTVP).....	2-5

## Maintenance

Maintenance.....	3-1
Related Maintenance Procedures .....	3-1
Preparation.....	3-1
Inspection and Cleaning.....	3-2
Removal and Installation Procedures.....	3-6
Preparation.....	3-6
Access Procedure .....	3-11
Procedures for External Modules .....	3-12
Procedure for Board Modules .....	3-19
Procedure for Internal Modules .....	3-28
Verifying the BIOS Configuration .....	3-36
Procedure .....	3-36

Troubleshooting .....	3-38
System Software Recovery .....	3-47
Recovery Procedure .....	3-47

## Diagrams

Diagrams .....	4-1
Optional Module Diagram .....	4-4
GbE (Option IPTVP) .....	4-4

## Replaceable Parts List

Replaceable Parts List .....	5-1
Parts Ordering Information .....	5-1
Using the Replaceable Parts List .....	5-3



---

# List of Figures

Figure 3-1: MTS400P orientation .....	3-8
Figure 3-2: External modules .....	3-9
Figure 3-3: Board modules .....	3-9
Figure 3-4: Internal modules .....	3-10
Figure 3-5: Cabinet removal .....	3-13
Figure 3-6: Right-side and left-side covers removal .....	3-15
Figure 3-7: Front-panel unit removal .....	3-17
Figure 3-8: Disassembly of front-panel assembly .....	3-19
Figure 3-9: Interface modules, A12 Main board, CPU board, and A20 PCI Backplane board removal .....	3-20
Figure 3-10: Attaching an optical cable to the SFP module. ....	3-23
Figure 3-11: Removing the SFP module.....	3-23
Figure 3-12: Instrument ID Setup dialog .....	3-25
Figure 3-13: Hard disk drive removal.....	3-29
Figure 3-14: Internal and external fan removal .....	3-31
Figure 3-15: 12 V main power supply and A40 AC Distributor board removal .....	3-33
Figure 3-16: RFI filter removal .....	3-35
Figure 3-17: Troubleshooting procedure (1) .....	3-39
Figure 3-18: Troubleshooting procedure (2) .....	3-40
Figure 3-19: Troubleshooting procedure (3) .....	3-41
Figure 3-20: Troubleshooting procedure (4) .....	3-42
Figure 3-21: Troubleshooting procedure (5) .....	3-43
Figure 3-22: Troubleshooting procedure (6) .....	3-44
Figure 3-23: Troubleshooting procedure (7) .....	3-45
Figure 3-24: A20 PCI Backplane board view-back side .....	3-46
Figure 3-25: A20 PCI Backplane board view-right side .....	3-46
Figure 4-1: MTS400P block diagram .....	4-2
Figure 4-2: MTS400P interconnect diagram .....	4-3
Figure 4-3: Option IPTVP (GbE) module connections .....	4-4
Figure 5-1: Cabinet and covers .....	5-5
Figure 5-2: Internal modules .....	5-7
Figure 5-3: Internal board modules .....	5-9
Figure 5-4: Front-panel unit.....	5-11
Figure 5-5: Cables.....	5-13

## List of Tables

Table 3-1: External inspection check list .....	3-3
Table 3-2: Internal inspection check list .....	3-4
Table 3-3: Summary of procedures.....	3-7
Table 3-4: Tools required for module removal .....	3-7
Table 5-1: Cabinet and covers .....	5-4
Table 5-2: Internal modules .....	5-6
Table 5-3: Replaceable parts list - Board modules.....	5-8
Table 5-4: Front-panel unit .....	5-10
Table 5-5: Replaceable parts list - Cables .....	5-12
Table 5-6: Accessories .....	5-14

# General Safety Summary

Review the following safety precautions to avoid injury and prevent damage to this product or any products connected to it.

To avoid potential hazards, use this product only as specified.

*Only qualified personnel should perform service procedures.*

While using this product, you may need to access other parts of a larger system. Read the safety sections of the other component manuals for warnings and cautions related to operating the system.

## To Avoid Fire or Personal Injury

**Use Proper Power Cord.** Use only the power cord specified for this product and certified for the country of use.

**Ground the Product.** This product is grounded through the grounding conductor of the power cord. To avoid electric shock, the grounding conductor must be connected to earth ground. Before making connections to the input or output terminals of the product, ensure that the product is properly grounded.

**Observe All Terminal Ratings.** To avoid fire or shock hazard, observe all ratings and markings on the product. Consult the product manual for further ratings information before making connections to the product.

The inputs are not rated for connection to mains or Category II, III, or IV circuits.

**Power Disconnect.** The power cord disconnects the product from the power source. Do not block the power cord; it must remain accessible to the user at all times.

**Do Not Operate Without Covers.** Do not operate this product with covers or panels removed.

**Do Not Operate With Suspected Failures.** If you suspect that there is damage to this product, have it inspected by qualified service personnel.

**Avoid Exposed Circuitry.** Do not touch exposed connections and components when power is present.

**Use Proper Fuse.** Use only the fuse type and rating specified for this product.

**Do Not Operate in Wet/Damp Conditions.**

**Do Not Operate in an Explosive Atmosphere.**

**Keep Product Surfaces Clean and Dry.**

**Provide Proper Ventilation.** Refer to the manual's installation instructions for details on installing the product so it has proper ventilation.

## Terms in this Manual

These terms may appear in this manual:



---

**WARNING.** *Warning statements identify conditions or practices that could result in injury or loss of life.*

---



---

**CAUTION.** *Caution statements identify conditions or practices that could result in damage to this product or other property.*

---

### Symbols and Terms on the Product

These terms may appear on the product:

- DANGER indicates an injury hazard immediately accessible as you read the marking.
- WARNING indicates an injury hazard not immediately accessible as you read the marking.
- CAUTION indicates a hazard to property including the product.

The following symbol(s) may appear on the product:

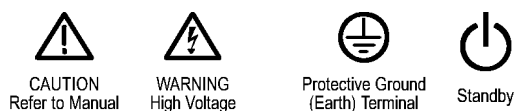

# Service Safety Summary

Only qualified personnel should perform service procedures. Read this *Service Safety Summary* and the *General Safety Summary* before performing any service procedures.

**Do Not Service Alone.** Do not perform internal service or adjustments of this product unless another person capable of rendering first aid and resuscitation is present.

**Disconnect Power.** To avoid electric shock, switch off the instrument power, then disconnect the power cord from the mains power.

**Use Care When Servicing With Power On.** Dangerous voltages or currents may exist in this product. Disconnect power, remove battery (if applicable), and disconnect test leads before removing protective panels, soldering, or replacing components.

To avoid electric shock, do not touch exposed connections.



# Preface

This is the service manual for the MTS400P Portable MPEG Test System. This manual contains information needed to service an MTS400P to the module level.

## Manual Structure

This manual is divided into sections, such as Theory of Operation and Maintenance. Further, some sections are divided into subsections, such as Product Description and Removal and Installation Procedures.

Sections containing procedures also contain introductions to those procedures. Be sure to read these introductions because they provide information needed to do the service correctly and efficiently. The following are brief descriptions of each manual section.

- *Theory of Operation* contains circuit descriptions that support service to the module level.
- *Maintenance* contains information and procedures for performing preventive and corrective maintenance of an MTS400P. These instructions include cleaning, module removal and installation, and fault isolation to the module level.
- *Diagrams* contains the block diagrams and interconnection diagrams of the MTS400P and the optional interface module.
- *Replaceable Parts List* includes a table of all replaceable modules, their descriptions, and their Tektronix part numbers, and illustrations to identify the modules.

## Manual Conventions

This manual uses certain conventions with which you should become familiar.

Some sections of the manual contain procedures for you to perform. To keep those instructions clear and consistent, this manual uses the following conventions:

- Instruction steps are numbered unless there is only one step.
- **Bold** text refers to specific interface elements that you are instructed to select, click, or clear.

Example: Press the **Menu** button to open the **File** menu.

- *Italic* text refers to document names or sections. Italics are also used in NOTES, CAUTIONS, and WARNINGS.















Example: The *Diagrams* section includes a block diagram and an interconnect diagram.

**Modules** Throughout this manual, any replaceable component, assembly, or part of the **MTS400P** is referred to generically as a module. In general, a module is an assembly (like a circuit board), rather than a component (like a resistor or an integrated circuit). Sometimes a single component is a module. For example, the chassis of the **MTS400P** is a module.

**Safety** Symbols and terms related to safety are defined in the *General Safety Summary*.

## Documentation

This manual provides information to troubleshoot and repair an MTS400P MPEG Test System to a module level. The following information is also available for this product:

Item	Purpose	Location
MTS400P Quick Start User Manual (071-2610-xx English, 071-2611-xx Japanese)	Provides installation and high-level operational overviews	 +  +  www.Tektronix.com
MTS400P Specifications and Performance Verification Technical Reference (077-0202-xx)	Provides complete product specifications and a procedure for verifying the operation of the instrument	 +  www.Tektronix.com
MTS400 Series Analyzer Applications User Manual (077-0205-xx)	Describes the operation of the following analyzer applications: TSCA, PES Analyzer, T-STD Buffer Analyzer, and ES Analyzer	 +  www.Tektronix.com
MTS400 Series Generator Applications User Manual (077-0204-00)	Describes the operation of the following generator applications: Multiplexer, MPEG Player, TS Editor, Make Seamless Wizard, Transport Stream Cutter, and Script Pad	 +  www.Tektronix.com
MTS400 Series Carousel Applications User Manual (077-0203-XX)	Describes the operation of the Carousel Analyzer and Carousel Generator applications	 +  www.Tektronix.com
MTS400 Series Programmer Manual (077-0206-XX)	Describes the programmer commands for controlling the MPEG Player application	 +  www.Tektronix.com
MTS400P Declassification and Security Instructions (077-0209-xx)	Provides instructions for removing your proprietary information from the instrument	 www.Tektronix.com
MTS400 Series Release Notes (077-0200-xx)		 www.Tektronix.com

User documents can be downloaded from the Tektronix Web site: [www.tektronix.com/manuals](http://www.tektronix.com/manuals).



---

# Introduction



---

# Introduction

This manual contains information needed to properly service the MTS400P Portable MPEG Test System, as well as general information critical to safe and effective servicing.

To prevent personal injury or damage to the MTS400P, consider the following before beginning the service:

- The procedures in this manual should be performed only by a qualified service person.
- Read the *General Safety Summary* and the *Service Safety Summary*.

When using this manual for servicing, be sure to follow all warnings, cautions, and notes.

## Strategy for Servicing

Throughout this manual, the term "module" refers to any field-replaceable component, assembly, or part of the MTS400P.

This manual contains all the information needed for periodic maintenance of the MTS400P (examples of such information are procedures for checking performance).

Further, this manual contains all information for corrective maintenance down to the module level. To isolate a failure to a module, use the fault isolation procedures found in Troubleshooting, part of section 3, *Maintenance*. To remove and replace any failed module, follow the instructions in the *Removal and Installation Procedures*, also part of section 3. After isolating a faulty module, replace it with a fully-tested module obtained from the factory. Section 5, *Replaceable Parts List*, contains part number and ordering information for all replaceable modules.

## Tektronix Service Offerings

Tektronix provides service to cover repair under warranty as well as other services that may provide a cost-effective answer to your service needs.

### Warranty Repair Service

The warranty appears after the title page in this manual. Tektronix technicians provide warranty service at most Tektronix service locations. The Tektronix product catalog lists all worldwide service locations or you can visit our Web site for service information: [www.tektronix.com](http://www.tektronix.com).

### Self Service

Tektronix supports repair to the module level by providing Module Exchange.

**Module Exchange.** This service reduces down-time for repair by allowing you to exchange most modules for remanufactured ones. Each module comes with a 90-day service warranty.

**For More Information.** Contact your local Tektronix service center or sales engineer for more information on any of the repair or adjustment services just described.

## Product Overview

The MTS400P Portable MPEG Test System analyzes and plays MPEG-2 transport streams that are compliant with ATSC, DVB, and ARIB standards.

The MTS400P provides the following features:

- Supports a wide range of DTV standards, including MPEG, DVB, ATSC, ISDB and ISDB-TB (Brazil). Specific SI for Terrestrial, Cable and Satellite, and regional variations of these standards
- A range of interfaces and analysis capabilities provide the necessary connectivity to diagnose problems anywhere in the network environment, including RF or IP layer transmission links or transport stream content processing
- Integrated cross-layer fault analysis and logging provide a single box solution for fault diagnosis, reducing time to insight when troubleshooting
- The playout functionality can simulate IP multisession replication to characterize behavior of a network or device under test
- CaptureVu™ technology captures and analyzes system events in real- and off-line time
- An innovative program-centric user interface brings expert power to the novice user
- H.264 Buffer Analysis, multiplexing and elementary stream compliance checking provide a powerful suite of tools for creation and analysis of transport streams containing H.264 content

All in a portable platform for field-based use.



---

# Theory of Operation





---

# Theory of Operation

This section describes the basic operation of the major circuit blocks or modules in the MTS400P. The Diagrams section includes a block diagram and an interconnect diagram.

## A12 Main Board

The A12 Main board consists of the following blocks:

- PCI Interface** The PCI interface consists of a PCI target and a PCI master. The PCI target has three base address register areas. The PCI master has two DMA controllers used to transfer data from the A12 Main board to the system memory or from the system memory to the A12 Main board.
- Mega FIFO** The Mega FIFO has 32 MB for playing and 32 MB for recording a stream data. It consists of two 256 megabit synchronous DRAM and FPGA. This FIFO is used to compensate for non-realtime operation of Windows XP.
- TS Controller** The TS controller consists of the following blocks:
- TS Packet Type Controller.** This controller sets a packet size of 188, 204, 208, and Non TS (free length) as a TS packet type. For a Non TS format, the controller also sets a packet length (16-255) and data length (16-255). The data length shows an effective data length in one TS packet.
  - Data Valid Controller.** This block generates a data valid signal that synchronizes with the first byte of a TS packet when stream output is started.
  - Psync Controller.** Psync is a signal to identify the sync byte in a transport stream. When the controller is not in the Psync Regeneration mode, Psync is recognized as the first byte of a transport stream. In this case, Psync is output in the constant interval even when the sync byte is rewritten in the value except for 0x47. For the Super Frame mode, Psync is output only once in 384 packets.
  - Psync Regenerator.** This block becomes active when the Psync Regeneration mode is set. The block detects the sync byte (0x47) in a data stream and regenerates a Psync signal. The psync generator supports 188, 204, 208 TS packets only.
  - PCR/DTS Updater.** This block consists of a PCR counter and update logic. The PCR counter is a complex counter, which consists of a 9-bit counter (range 0-299) and a 33-bit counter. The counter counts the 27 MHz standard frequency. The update logic replaces the PCR and PTS/DTS values in a transport stream with the sum of the original value and the PCR counter value.

**Receive Rate Counter.** This 24-bit counter is used for receive-rate calculation on the recording process. When using a data valid signal (DVALID), the counter counts byte data rate. When not using DVALID, the counter counts the receive clock.

**Transmit Byte Counter.** This 32-bit counter counts transmitted bytes. This counter can be read by the control software.

**Interrupt Controller** The interrupt controller sends the following interruption signals to the CPU: Play FIFO empty, Record FIFO full, external trigger, 10 Hz, Playout DMA transfer finished, and Record DMA transfer finished. These signals can be disabled by the MTS400P application software. At power on, all interruptions are disabled.

**TS Clock Generator** The TS clock generator consists of a VCO (Voltage Control Oscillator), a phase detector, and a frequency divider. The VCO is used for generating a TS clock, and it covers frequencies of 400 MHz to 800 MHz. The frequency divider divides the clock by 65536 to 1.

**Reference Clocks** The reference clocks consist of 27 MHz TCXO and half-divided output of 54 MHz clock generator. These clocks are used to compare the frequency of the TS Clock Generator.

## A20 PCI Backplane Board

The A20 PCI Backplane board consists of the following connectors and circuits:

**PCI and ISA Connectors** Connectors J100, J110, and J120 are 5 V PCI slots, while connector J130 is a 3.3 V PCI slot. Connector J100 is the system slot, where the CPU board, a single board Computer (SBC), is installed. The A12 Main board is installed into connector J110. Connector J120 is used to install one of the optional input interface boards, Options 01, 02, 05, or 07. Connector J130 is reserved for an Option IPTVP GbE board. If Option IPTVP is installed, the Option 07 SMPTE310M/ASI/PSI Interface must be installed as well.

**ATX Power Control Circuit** The PWR\_Button line (Pins 9 and 10 of J310) of the SBC is connected to the power switch on the Keypad board through the Front-Panel Processor board. When the power switch is pressed, the SBC causes the PSON# signal to go Low. When the PSON# signal becomes Low, Q10 turns on and +12 V main power is also on. When the power switch is pressed again, its status is sent to BIOS and the PSON# signal turns High. This circuit includes a +12 V to +5 V DC-DC converter, a +12 V to +3.3 V converter, and a +12 V to -12 V converter.

<b>Interconnect Circuit</b>	There are four connectors in the interconnect circuit: J230, J240, J290, and J310. J230 is used to connect the board to the LCD interface on the CPU board. J290 is used to connect the board to COM2 on the CPU board. J310 is used to connect the board to the hard disk drive LED and reset/power button on the CPU board. J240 is used to connect the board to the Front-Panel Processor board. This circuit also has a RS-232C level converter.
<b>Fan Speed Control Circuit</b>	U700 (PIC Micro) controls the internal fan revolution. It gets the temperature data from the sensors (U720 and U730) through 1 <sup>2</sup> C BUS and controls the supply voltage to the fan (7 V to 11.5 V).
<b>IEEE1394b Interface</b>	The IEEE1394 interface consists of the 1394b link-layer device (U110), cable transceiver/arbiter (U120), oscillator (Y100), serial EEPROM (U140), regulators (U130 and U230), and IEEE1394b connector (J140).

## Front-Panel Processor Board

The Front-Panel Processor board consists of the following circuitries and connectors:

<b>Front-panel Keypad Interface and LED Control</b>	The state of the front-panel keys is read by the one-chip processor on the board and any setting changes are reported to the SBC through the COM2. The processor also controls the LED on/off state of the front-panel LEDs.
<b>LVDS Data for LCD</b>	The LVDS data from the SBC is routed through the board to the LCD.
<b>Backlight Power Control</b>	When the Window OS puts the instrument into power saver mode, the LVDS data from the SBC stops and the LCD backlight needs to be turned off or a rainbow display will occur. When the LVDS data stops, the common mode voltage of the data lines changes from the normal +1.25 V to 0 V. The comparator U10 senses this voltage change and turns off the power MOSFET switch Q10 and the power to the backlight inverter board.
<b>LCD Brightness Control</b>	The potentiometer R301 could be used to dim the LCD backlight brightness. But R302 is not installed, so the adjustment has no effect and the backlight is at maximum brightness.
<b>USB Ports</b>	There are two USB connectors on the board that are connected through a cable to the USB 2.0 interface connector on the CPU board.

## Keypad Board

The Keypad board contains the switch patterns for the elastomer keys and the front-panel LEDs. The board is connected to the Front-Panel Processor board by the board-to-board connectors J10 and J11.

## A40 AC Distributor Board

The A40 AC Distributor board supplies standby power (5VSB) to the SBC and the ATX power control circuit on the A20 Backplane board.

## A170 SMPTE310M/ASI/PSI Interface Module

**SMPTE310M** The SMPTE310M format supports data with a bit rate of 8-VSB (19.39 Mbps). Because the SMPTE310M uses Biphase-mark coding, a clock with twice the data bit rate (40 MHz) is required for decoding and encoding processes. The receiver passes the received data signal through a delay line to generate a clock signal with twice the data bit rate from the received data signal. The transmitter receives the clock signal with twice the data bit rate from A12 board for data encoding. Because this optional board is unable to recognize the difference of data bit rates, the current data bit rate must be specified from the application.

**Packet Controller** Two operational modes are available to output data from the ASI interface: Packet mode and Byte mode.

**Difference between Packet and Byte Modes.** The data rate of the ASI interface is up to 216 Mbps, and data with rates lower than 216 Mbps are transmitted intermittently. The Data Valid signal, which indicates the location in which the data exists, is also sent together with the data. It is possible to reconfigure the received data as a serial data string from the intermittently transmitted data.

When the data rate from the MTS400P storage (hard disk or RAM) is lower than 216 Mbps, it is possible to select whether to sparsely output all the data or to output the data on a packet-by-packet basis as the ASI output. The first mode in which the data is sparsely output is called Byte mode, and the second mode in which the data is output on a packet-by-packet basis is called Packet mode. In Byte mode, the data sent from the A12 board are output as they are. In Packet mode, data processing is required.

**Packet Mode Operation.** The FIFO shift register is used to output the data on a packet-by-packet basis. This FIFO has 9 bits of width, and a depth of 512 stages. The content of 9-bit width is 8 bits for data, and 1 bit for Sync Bit. The Sync bit indicates the location of sync pattern (47h) in the data.

The data sent from the A12 board is fed to the FIFO. The FIFO output port searches for a Sync Bit. When a Sync Bit is detected, data output from the FIFO is stopped, and the data that follows the Sync Bit is stored in the FIFO.

The FIFO input port also searches for a Sync Bit. When the port detects a Sync Bit in the next packet, it sends the detection to the read-out controller at the FIFO output port. When the FIFO output port receives the Sync Bit detection signal from the input port, the output port reads out the signals until the next packet Sync Bit is detected. The data rate of FIFO input port is equal to the data transfer rate of the MTS400P, and that of the output port is 216 Mbps (with a clock of 27 MHz), which is used for the ASI output.

**A12 Board I/O** When receiving SMPTE310M or ASI data, both the enabling and 27 MHz clock signal are delivered to the A10 board. The Option 06 can convert the data from SMPTE310M into ASI, however it cannot to convert the ASI data into the SMPTE310M format.

To transmit data in the SMPTE310M format, an enabling signal and clock signal (approximately 77.56 MHz) for encoding the Biphase-mark are required. When transmitting data in the ASI format, the enabling signal, the signal indicating the location of sync bit, and the transport stream clock are generated from the A10 board.

## GbE Interface Module (Option IPTVP)

**Interface Communication** Communication with any interface board is functionally similar. Input and Output connectors are provided. The output connector is a loop-through of the input. The GbE interface module uses a Common Interface Program (CIP), and the transport stream data is externally connected from the GbE module ASI Out connector to the Transport Stream Processor's ASI In connector.

**Interface Boards** The GbE card supports an interface for the packet-based Internet Protocol (IP) standard using the Gigabit Ethernet (GbE) optical and electrical physical layer interfaces. The main function of the board is to filter the selected Transport Stream from an electrical or optical GbE input to the ASI output, which is then connected externally to the ASI input of the Transport Stream Processor board for MPEG monitoring.

The Ethernet Interface to the board is an IEEE 802.3 compliant 10/100/1000 Ethernet interface supporting 10/100/1000BT copper, and 1000BSX (multi-mode), 1000BLX (single-mode), and 1000BZX (single-mode) optical. There are 2 Ethernet interface ports available on the card, a standard copper RJ-45 interface and an optional MSA compliant SFP connector supporting the optical interface. The SFP connector is provided for pluggable optical interfaces. Only one interface port, either the copper or the optical, will be active at a time for video over IP monitoring. The active interface is selectable via SW control in the RUI.



---

# Maintenance





---

# Maintenance

This section contains the information needed to do periodic and corrective maintenance on the MTS400P. The following subsections are included:

- *Preparation*
- *Inspection and Cleaning*
- *Removal and Installation Procedures*
- *Verifying the BIOS Configuration*
- *Troubleshooting*
- *System Software Recovery*

## Related Maintenance Procedures

These sections contain information and procedures related to maintenance:

- *Theory of Operation*, contains a circuit description at the module or block level.
- *Diagrams*, contains a block diagram using individual modules as blocks and an interconnection diagram showing connections between the modules.
- *Replaceable Parts List*, lists all field replaceable modules by part number.

You may also refer to the *MTS100B Specifications and Performance Verification* manual, which contains procedures that may be useful in isolating problems to modules by testing the MTS400P performance. See the *MTS400P Specifications and Performance Verification Technical Reference*, available on the Tektronix Web site at [www.tektronix.com/manuals](http://www.tektronix.com/manuals).

## Preparation

Before servicing this product, read the *General Safety Summary*, *Safety Summary*, and *Introduction* at the front of the manual, and the following ESD information.



**CAUTION.** *Static discharge can damage any semiconductor component in the MTS400P.*

---

### Preventing ESD

When performing any service that requires internal access to the MTS400P, adhere to the following precautions to avoid damaging internal modules and their components due to electrostatic discharge (ESD).

1. Minimize handling of static-sensitive modules.
2. Transport and store static-sensitive modules in their static protected containers or on a metal rail. Label any package that contains static-sensitive modules.
3. Discharge the static voltage from your body by wearing a grounded antistatic wrist strap while handling these modules. Perform service of static-sensitive modules only at a static-free work station.
4. Nothing capable of generating or holding a static charge should be allowed on the work station surface.
5. Handle circuit boards by the edges when possible.
6. Do not slide the modules over any surface.
7. Avoid handling modules in areas that have a floor or work-surface covering capable of generating a static charge.

## Inspection and Cleaning

*Inspection and Cleaning* describes how to inspect for dirt and damage. It also describes how to clean the exterior and interior of the MTS400P. Inspection and cleaning are done as preventive maintenance. Preventive maintenance, when done regularly, may prevent the MTS400P from malfunctioning and enhance its reliability.

Preventive maintenance consists of visually inspecting and cleaning the MTS400P and using general care when operating it.

How often preventative maintenance should be performed depends on the severity of the environment in which the MTS400P is used.

### General Care

The cabinet helps keep dust out of the MTS400P, and is needed to meet EMI and cooling requirements. The cabinet should be in place when operating the MTS400P. The front cover protects the front panel and display from dust and damage. Install the front cover when storing or transporting the MTS400P.

### Inspection and Cleaning Procedures

Inspect and clean the MTS400P as often as operating conditions require. The collection of dirt on components inside can cause them to overheat and break down. Dirt acts like an insulating blanket, preventing efficient heat dissipation. Dirt also provides an electrical conduction path that could cause an MTS400P failure, especially under high-humidity conditions.



**CAUTION.** *Avoid the use of chemical cleaning agents that might damage the plastics used in this MTS400P. Use only deionized water when cleaning the menu buttons or front-panel buttons. Use an ethyl alcohol solution as a cleaner and rinse with deionized water. Use an ethyl alcohol solution as a cleaner and rinse with deionized water.*

**Inspection — Exterior.** Inspect the outside of the MTS400P for damage, wear, and missing parts, using the following table as a guide. An MTS400P that appears to have been dropped or otherwise abused should be checked thoroughly to verify correct operation and performance. Immediately repair defects that could cause personal injury or lead to further damage to the MTS400P.

**Table 3-1: External inspection check list**

Item	Inspect for	Repair action
Cabinet, front panel, and cover	Cracks, scratches, deformations, damaged hardware or gaskets.	Repair or replace defective module.
Front-panel buttons	Missing, damaged, or loose buttons.	Repair or replace missing or defective buttons.
Connectors	Broken shells, cracked insulation, and deformed contacts. Dirt in connectors.	Repair or replace defective modules. Clear or wash out dirt.
Accessories	Missing items or parts of items, bent pins, broken or frayed cables, and damaged connectors.	Repair or replace damaged or missing items, frayed cables, and defective modules.

**Cleaning Procedure – Exterior.** To clean the MTS400P exterior, perform the following steps:

1. Remove loose dust on the outside of the MTS400P with a lint free cloth.
2. Remove remaining dirt with a lint free cloth dampened in a general purpose detergent-and-water solution. Do not use abrasive cleaners.
3. Clean the light filter protecting the monitor screen with a lint-free cloth dampened with a gentle, general purpose detergent-and-water solution.



**CAUTION.** *To prevent getting moisture inside the MTS400P during external cleaning, use only enough liquid to dampen the cloth or applicator.*

**Inspection — Interior.** To access the inside of the MTS400P for inspection and cleaning, refer to the Removal and Installation Procedures in this section. (See page 3-6.)

Inspect the internal portions of the MTS400P before damage and wear, using the following table as a guide. Defects found should be repaired immediately.



**CAUTION.** *To prevent damage from electrical arcing, ensure that circuit boards and components are dry before applying power to the MTS400P.*

**Table 3-2: Internal inspection check list**

<b>Item</b>	<b>Inspect for</b>	<b>Repair action</b>
Circuit boards	Loose, broken, or corroded solder connections. Burned circuit boards. Burned, broken, or cracked circuit-run plating.	Remove failed module and replace with a fresh module.
Resistors	Burned, cracked, broken, blistered condition.	Remove failed module and replace with a fresh module.
Solder connections	Cold solder or rosin joints.	Resolder the joint and clean with isopropyl alcohol.
Capacitors	Damaged or leaking cases. Corroded solder on leads or terminals.	Remove damaged module and replace with a fresh module from the factory.
Semiconductors	Loosely inserted in sockets. Distorted pins.	Firmly seat loose semiconductors. Remove devices that have distorted pins. Carefully straighten pins (as required to fit the socket), using long-nose pliers, and reinsert firmly. Ensure that straightening action does not crack pins, causing them to break off.
Wiring and cables	Loose plugs or connectors. Burned, broken, or frayed wiring.	Firmly seat connectors. Repair or replace modules with defective wires or cables.
Chassis	Dents, deformations, and damaged hardware.	Straighten, repair, or replace defective hardware.

**Cleaning Procedure — Interior.** To clean the MTS400P interior, perform the following steps:

1. Blow off dust with dry, low-pressure, deionized air (approximately 9 psi).
2. Remove any remaining dust with a lint-free cloth dampened in ethyl alcohol and rinse with warm deionized water. (A cotton-tipped applicator is useful for cleaning in narrow spaces and on circuit boards.)

---

**NOTE.** *If, after performing steps 1 and 2, a module is clean upon inspection, skip the remaining steps.*

---

3. If steps 1 and 2 do not remove all the dust or dirt, the MTS400P may be spray washed using a solution of ethyl alcohol by performing steps 4 through 8.
4. Gain access to the parts to be cleaned by removing easily accessible shields and panels.
5. Spray wash dirty parts with the ethyl alcohol and wait 60 seconds for the majority of the alcohol to evaporate.
6. Use hot (120 °F to 140 °F) deionized water to thoroughly rinse them.
7. Dry all parts with low-pressure, deionized air.
8. Dry all components and assemblies in an oven or drying compartment using low-temperature (125 °F to 150 °F) circulating air.

**Lubrication.** There is no periodic lubrication required for the MTS400P.

## Removal and Installation Procedures

This section contains procedures for removal and installation of all mechanical and electrical modules.

### Preparation



---

**WARNING.** Before performing this or any other procedure in this manual, read the Safety Summary found at the beginning of this manual. Also, to prevent possible damage to components of the MTS400P, read Preventing ESD in this section.

---

This subsection contains the following items:

- Preparatory information that you need to properly perform the procedures that follow.
- List of tools required to remove and disassemble all modules.
- Three module locator diagrams for finding the External modules, Board modules, and Internal modules. (See Figure 3-2 on page 3-9.) (See Figure 3-4 on page 3-10.)
- Procedures for removal and reinstallation of the electrical and mechanical modules.
- A disassembly procedure for removal of all the major modules from the MTS400P at one time and for reassembly of those modules into the MTS400P. Such a complete disassembly is normally only done when completely cleaning the MTS400P. (Instructions for cleaning are found under *Inspection and Cleaning* at the beginning of this section.)



---

**WARNING.** Before performing any procedure in this subsection, disconnect the power cord from the line voltage source. Failure to do so could cause serious injury or death.

---

### General Instructions

The Summary of Procedures explains how the procedures are grouped, and Required Equipment lists the tools needed to remove and install modules in the MTS400P.

If you are removing a module for service, begin by performing the *Access Procedure*. By following the instructions in that procedure, you remove the module to be serviced while removing the minimum number of additional modules.

## Summary of Procedures

The procedures are described in the order in which they appear in this section. In addition, you can look up any procedure for removal and reinstallation of any module in the *Table of Contents*.

- The Access Procedure first directs you to the procedure(s) (if any) that are required to access the module to be serviced, then it directs you to the procedure to remove that module.

**Table 3-3: Summary of procedures**

Procedure	Module	Page	
Procedures for External Modules	■ Cabinet	■ Front-panel unit ■ Front-panel assembly	(See page 3-12, <i>Procedures for External Modules</i> .)
	■ Right-side cover		
	■ Left-side cover		
Procedures for Board Modules	■ A12 Main board	■ IPTVP (GbE) board (Optional) ■ Printer connector	(See page 3-19, <i>Procedure for Board Modules</i> .)
	■ CPU board		
	■ A20 PCI Backplane board		
Procedures for Internal Module	■ Hard disk drive	■ A40 AC Distributor board RFI filter	(See page 3-28, <i>Procedure for Internal Modules</i> .)
	■ Internal and external fans		
	■ 12 V main power supply		

**Required Equipment.** Most modules in this MTS400P can be removed with a screwdriver handle mounted with a size T10 TORX screwdriver tip. Use this tool whenever a procedure step instructs you to remove or install a screw unless a different size screwdriver is specified in that step.

All equipment required to remove and reinstall each module is listed in the first step of its procedure.

**Table 3-4: Tools required for module removal**

Item No.	Name	Description
1	Screwdriver handle	Accepts TORX driver bits
2	T10 TORX tip	TORX driver bit for T10 size screw heads
3	T15 TORX tip	TORX driver bit for T15 size screw heads
4	Nut driver, 1/4 inch	Standard tool

## MTS400P Orientation

In this manual, procedures refer to “front,” “rear,” and “top” of the MTS400P. The following figure shows how the sides are referenced.

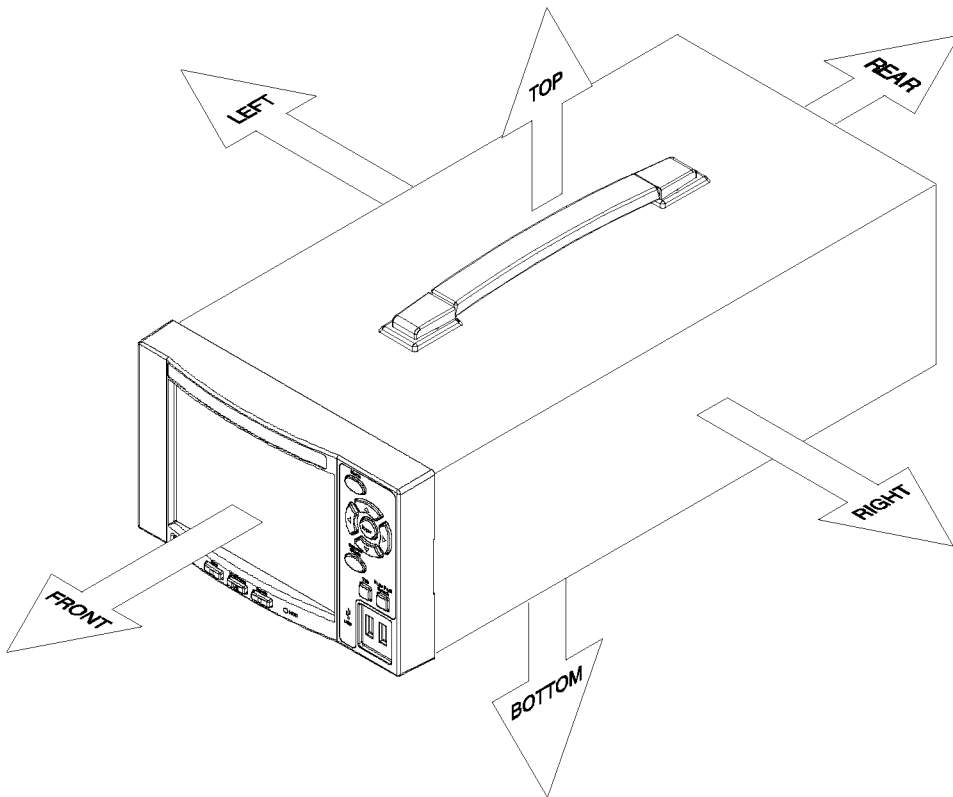

**Figure 3-1: MTS400P orientation**

The following figures show the modules that make up the MTS400P.



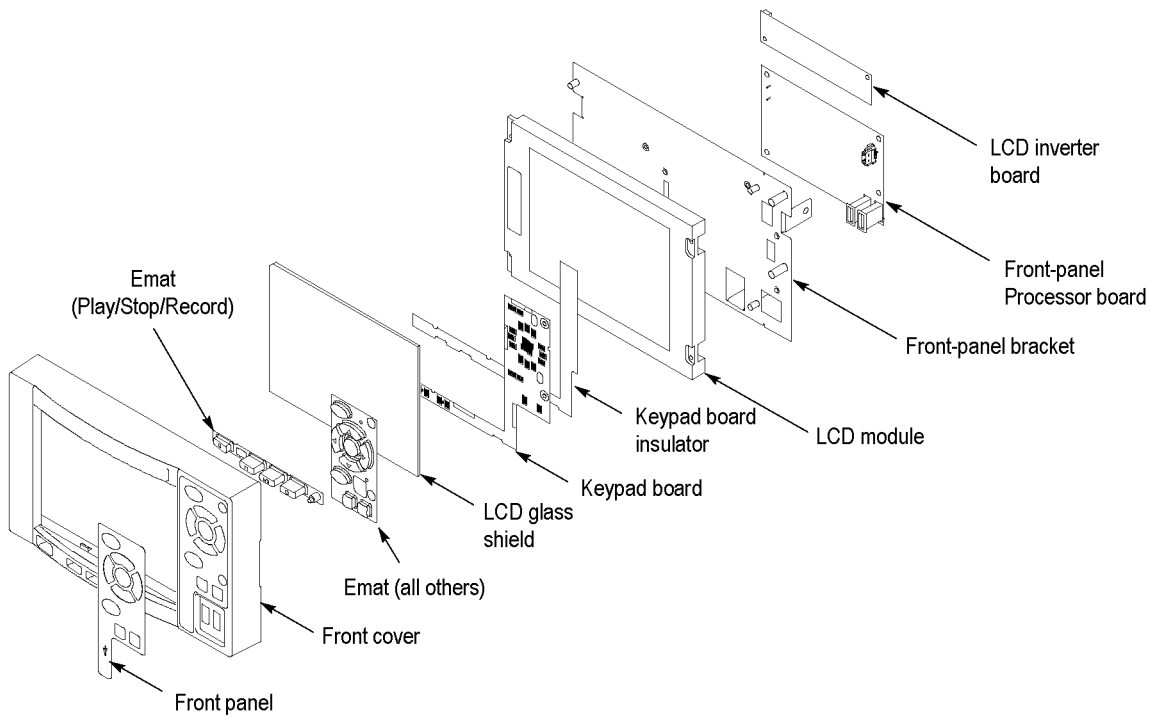
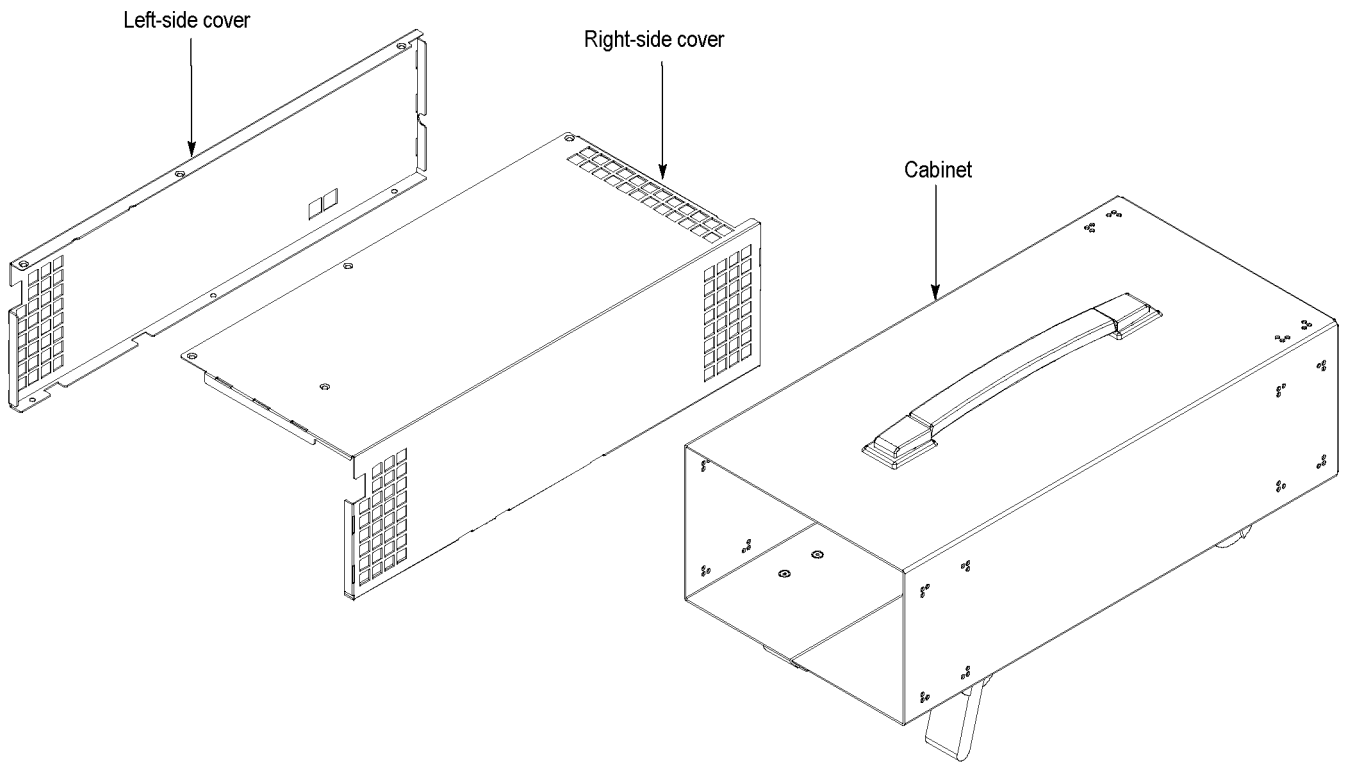
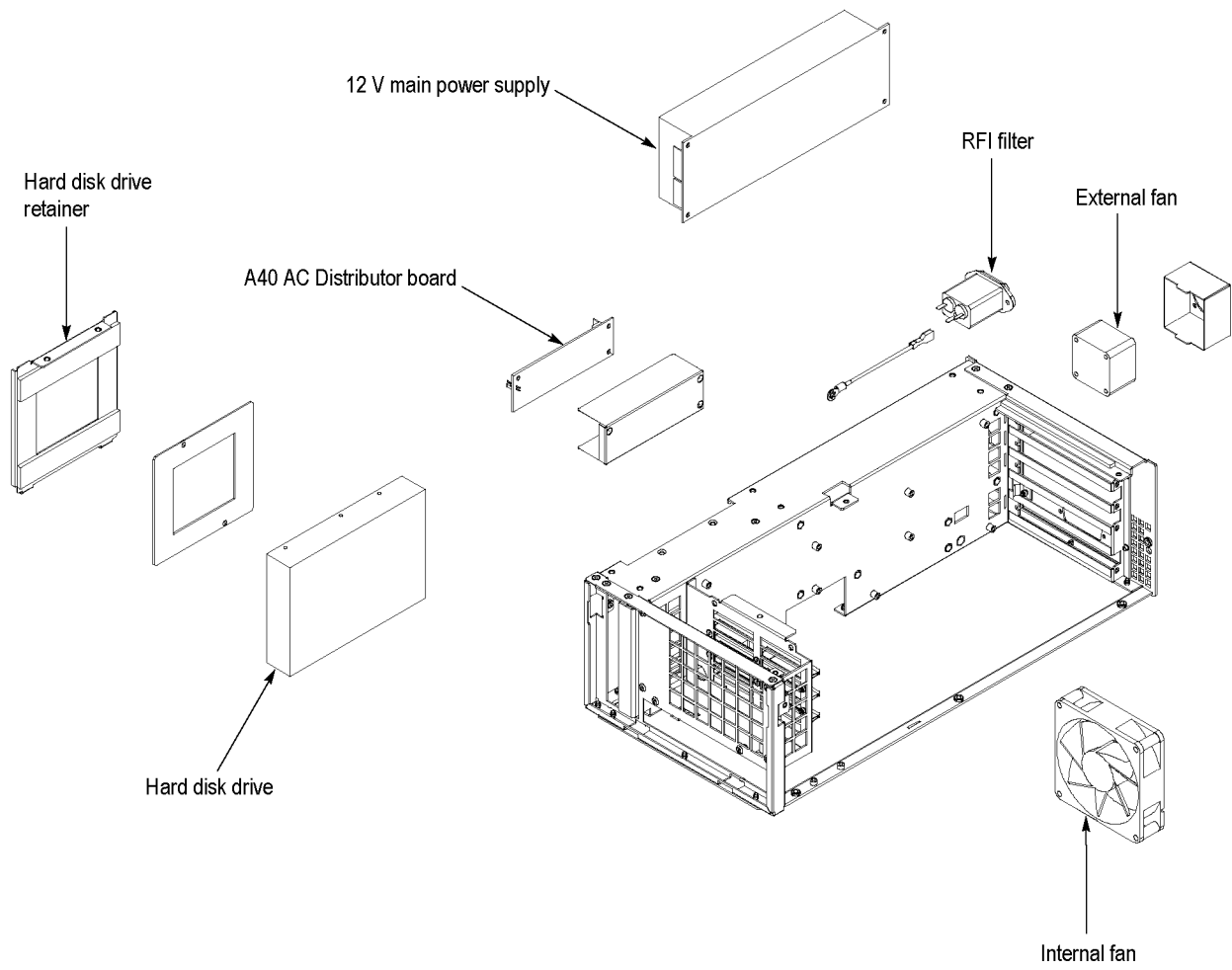

Figure 3-2: External modules

Figure 3-3: Board modules



**Figure 3-4: Internal modules**

## Access Procedure

Use the steps below to determine which procedures to use for removing the module. The removal procedures end with installation instructions.

1. Locate the module you want to remove in the three figures to determine whether it is an external module, a board module, or an internal module. (See Figure 3-2.) (See Figure 3-3.) (See Figure 3-4.)
2. Do the Cabinet procedure. (See page 3-12, *Cabinet*.)
3. Do the Right-Side Cover procedure. (See page 3-13, *Right-Side Cover*.)
4. Do the Left-Side Cover procedure. (See page 3-14, *Left-Side Cover*.)
5. If the module is part of the front panel, do these procedures as necessary:
  - Front-Panel Unit. (See page 3-16, *Front-Panel Unit*.)
  - Front-Panel Assembly. (See page 3-18, *Front-Panel Assembly*.)
6. If the module is a board module, do these procedures as necessary:
  - Optional Interface Module. (See page 3-21, *Option IPTVP (GbE)*.)
  - A12 Main Board. (See page 3-24, *A12 Main Board*.)
  - CPU Board. (See page 3-25, *CPU Board*.)
  - A20 PCI Backplane Board. (See page 3-26, *A20 PCI Backplane Board*.)
  - Printer connector. (See page 3-27, *Printer Connector*.)
7. If the module is an internal module, do these procedures as necessary:
  - Hard Disk Drive. (See page 3-28, *Hard Disk Drive*.)
  - Internal and External Fans. (See page 3-30, *Internal and External Fans*.)
  - 12 V Main Power Supply. (See page 3-32, *12 V Main Power Supply*.)
  - A40 AC Distribution Board. (See page 3-32, *A40 AC Distributor Board*.)
  - RFI Filter. (See page 3-34, *RFI Filter*.)

## Procedures for External Modules

Perform the *Access Procedure* before performing any procedure in this group. This group contains the following procedures:

- *Cabinet*
- *Right-side cover*
- *Left-side cover*
- *Front-panel unit*
- *Front-panel assembly*

- Cabinet**
1. Assemble the equipment and locate the module to be removed:
    - a. You need a screwdriver with a T15 TORX tip.
    - b. Locate the cabinet in the locator diagram *External modules*. (See Figure 3-2.)
  2. Orient the instrument: Set the MTS400P so that its bottom is down on the work surface and its rear is facing you.
  3. Use a screwdriver with a T15 TORX tip to remove the two screws securing the cabinet to the MTS400P. (See Figure 3-5.)
  4. Grasp the right and left edges of the cabinet toward the back. Push the chassis rear panel, toward the front of the MTS400P, to separate it from the cabinet.
  5. Slide the cabinet off the MTS400P.
  6. *Reinstallation:* Perform steps 3 through 5 in reverse order to reinstall the cabinet.

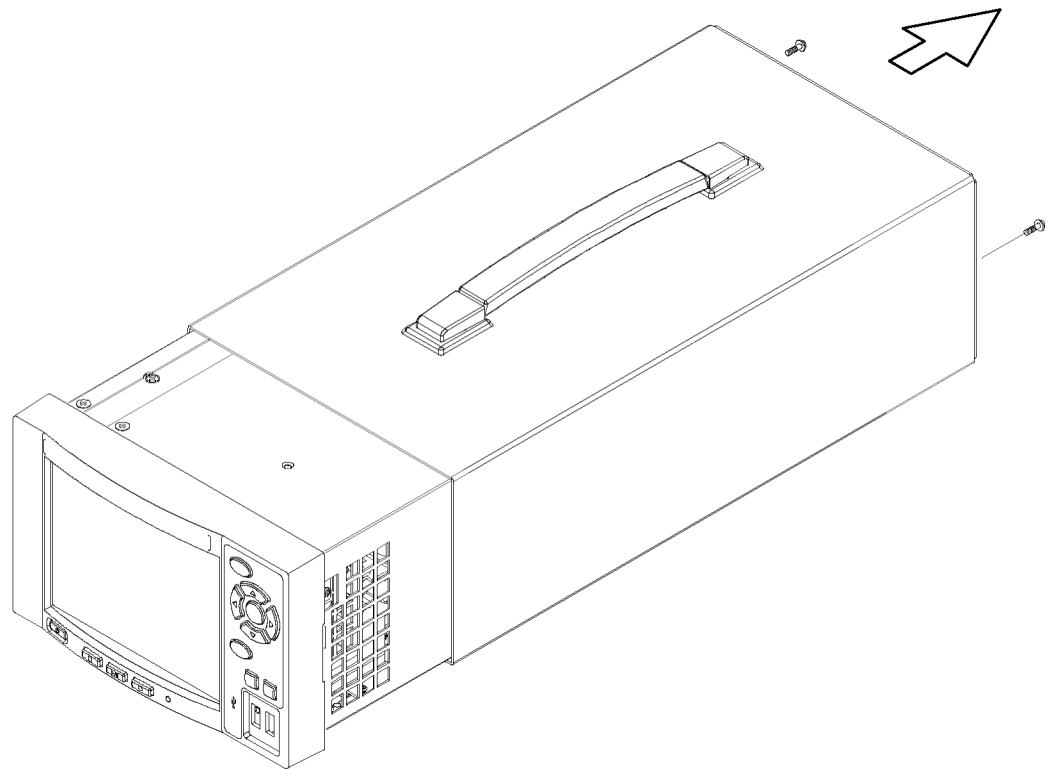

**Figure 3-5: Cabinet removal**

### **Right-Side Cover**

1. Assemble the equipment and locate the module to be removed:
  - a. You need a screwdriver with a T10 TORX tip.
  - b. Locate the right-side cover in the locator diagram *External modules*. (See Figure 3-2.)
2. Orient the instrument: Set the MTS400P so that its left side is down on the work surface and its front is facing you.
3. Use a screwdriver with a T10 TORX tip to remove the seven screws securing the right-side cover to the top and bottom of the chassis. (See Figure 3-6.)
4. Remove the right-side cover from the chassis.
5. Reinstallation: Perform steps 3 and 4 in reverse order to reinstall the right-side cover.

**Left-Side Cover**

1. Assemble the equipment and locate the module to be removed:
  - a. You need a screwdriver with a T10 TORX tip.
  - b. Locate the left-side cover in the locator diagram *External modules*. (See Figure 3-2.)
2. Orient the instrument: Set the MTS400P so that its right side is down on the work surface and its front is facing you.
3. Use a screwdriver with a T10 TORX tip to remove the six screws securing the left-side cover to the top and bottom of the chassis. (See Figure 3-6.)
4. Remove the left-side cover from the chassis.
5. Reinstallation: Perform steps 3 and 4 in reverse order to reinstall the left-side cover.

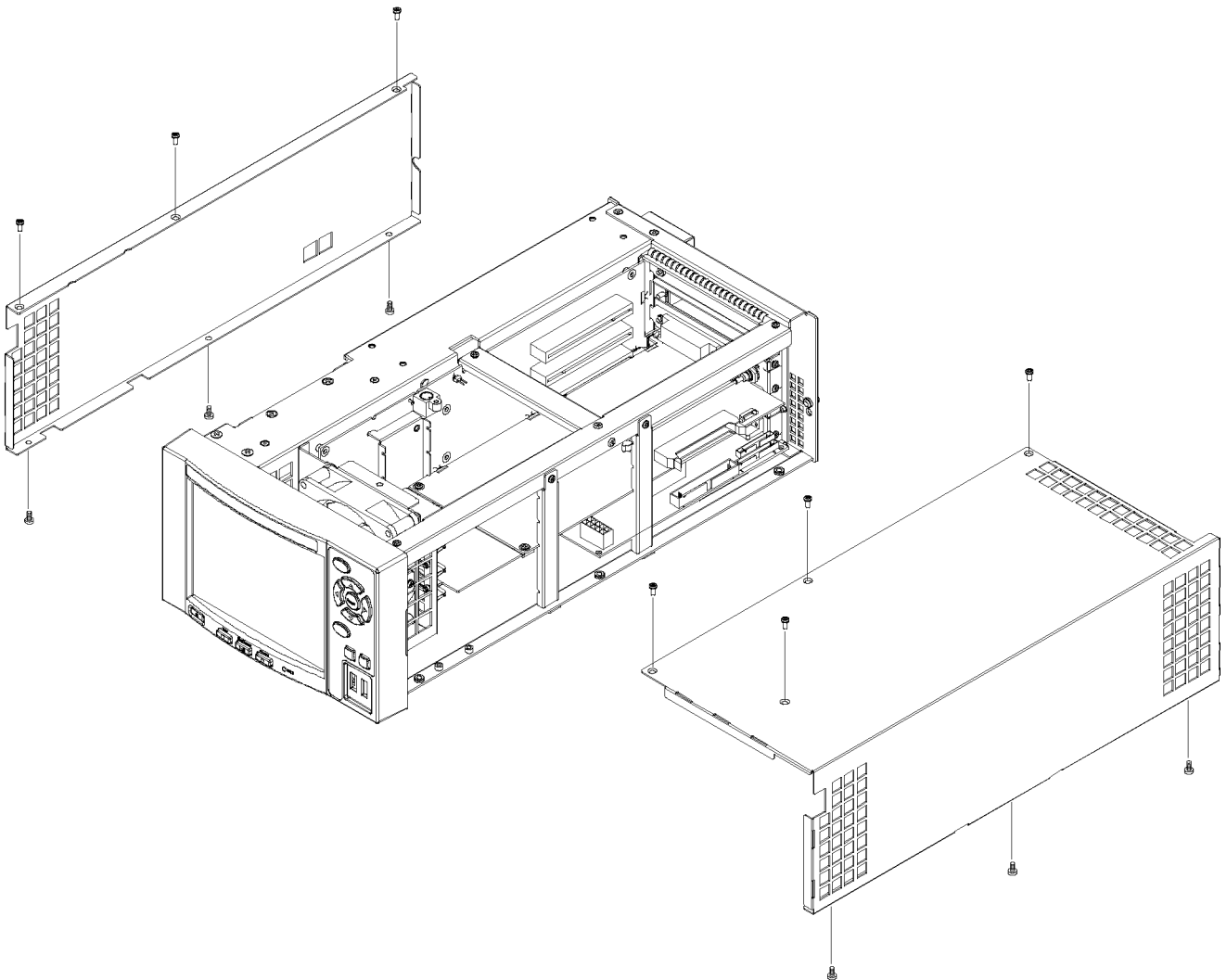

Figure 3-6: Right-side and left-side covers removal

- Front-Panel Unit**
1. Assemble the equipment and locate the module to be removed:
    - a. You need a screwdriver with a T10 TORX tip.
    - b. Locate the front-panel unit in the locator diagram *External modules*. (See Figure 3-2.)
  2. Orient instrument: Set the MTS400P so that its bottom is down on the work surface and its front is facing you.
  3. Remove front-panel unit: (See Figure 3-7.)
    - a. Use a screwdriver with a T10 TORX tip to remove the four screws securing the front-panel unit to the chassis.
    - b. Grasp the front-panel unit and pull it forward.
    - c. Disconnect the cable from J100 on the Front-Panel Processor board.
    - d. Disconnect the cable from J105 on the Front-Panel Processor board.
  4. Reinstallation: Perform step 3 in reverse order to reinstall the front-panel unit.



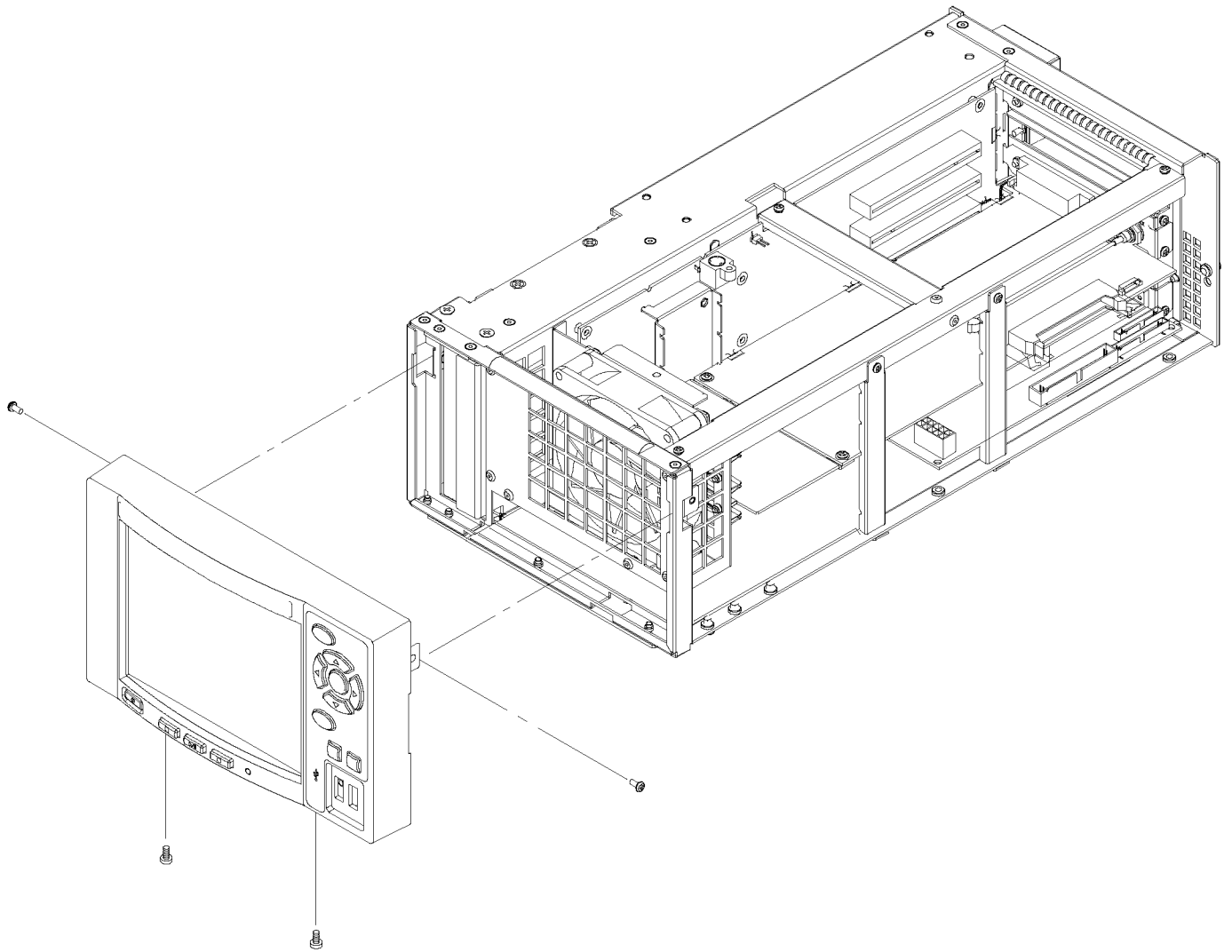

Figure 3-7: Front-panel unit removal

## Front-Panel Assembly

1. Assemble the equipment and locate the module to be removed:
  - a. You need a screwdriver with a T10 TORX tip.
  - b. Locate the front-panel assembly in the locator diagram *External modules*. (See Figure 3-2.)
2. Remove the front cover:

(See Figure 3-8.)

  - a. Press the two latches at the bottom of the front cover to release it from the front cover bracket.
  - b. Pull the front cover forward, away from the front-panel bracket.
3. Remove the Front-Panel Processor board: (See Figure 3-8.)
  - a. Disconnect the cables from J11, J301, and J321 on the Front-Panel Processor board.
  - b. Use a screwdriver with a T10 TORX tip to remove the four screws securing the Front-Panel Processor board to the front-panel bracket.
  - c. Lift the board away.
4. Remove the Keypad board: (See Figure 3-8.)
  - a. Use a screwdriver with a T10 TORX tip to remove the two screws securing the Keypad board to the front-panel bracket.
  - b. Lift the board away.
5. Remove the LCD module: (See Figure 3-8.)
  - a. Use a screwdriver with a T10 TORX tip to remove the four screws securing the LCD module to the front-panel bracket.
  - b. Lift the LCD module away.
6. Manually disassemble the front-panel assembly components using the figure as a guide. (See Figure 3-8.) Reverse the procedure to reassemble.
7. Reinstallation: Perform steps 3 through 6 in reverse order to reinstall the front-panel assembly.

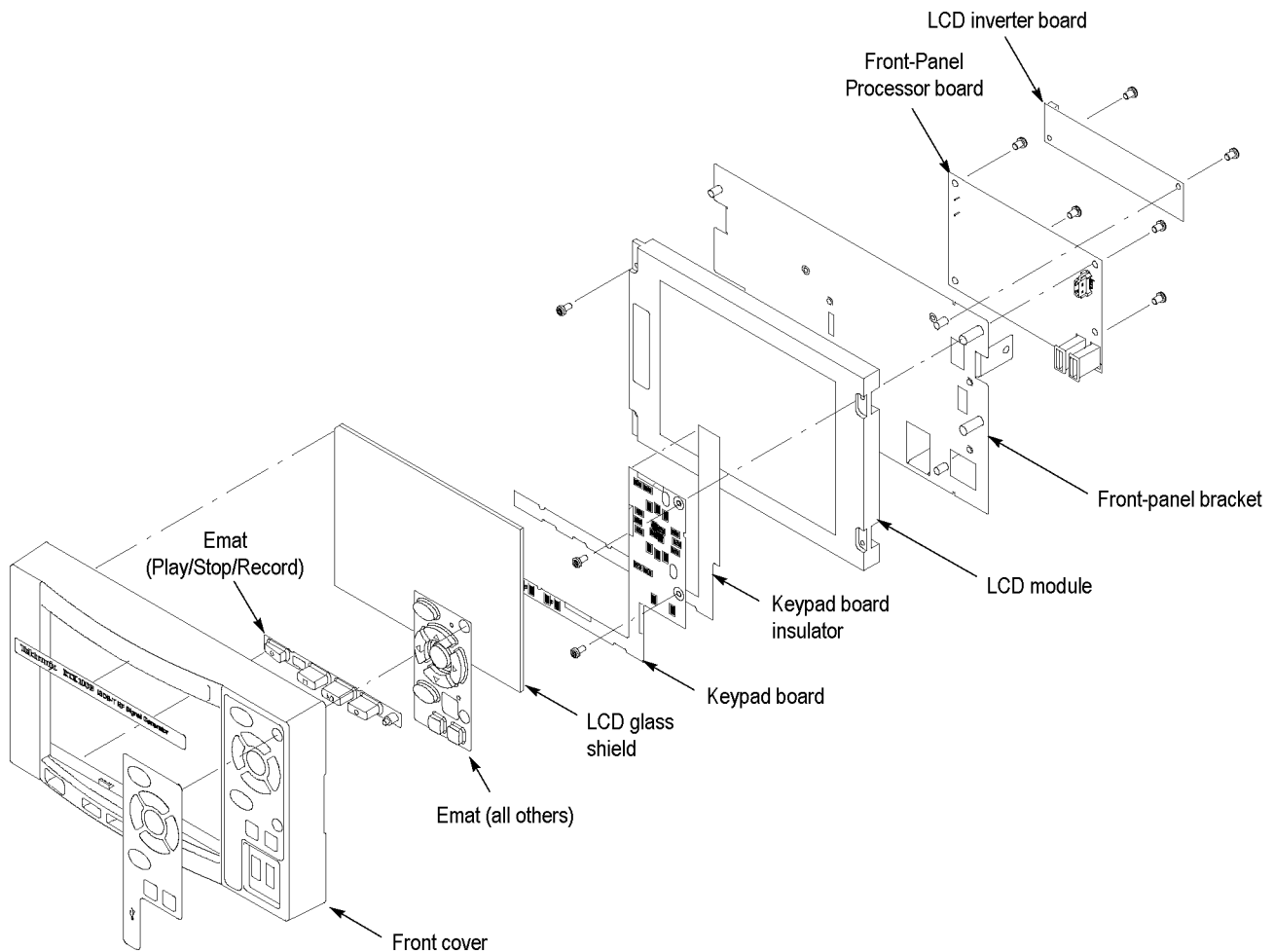
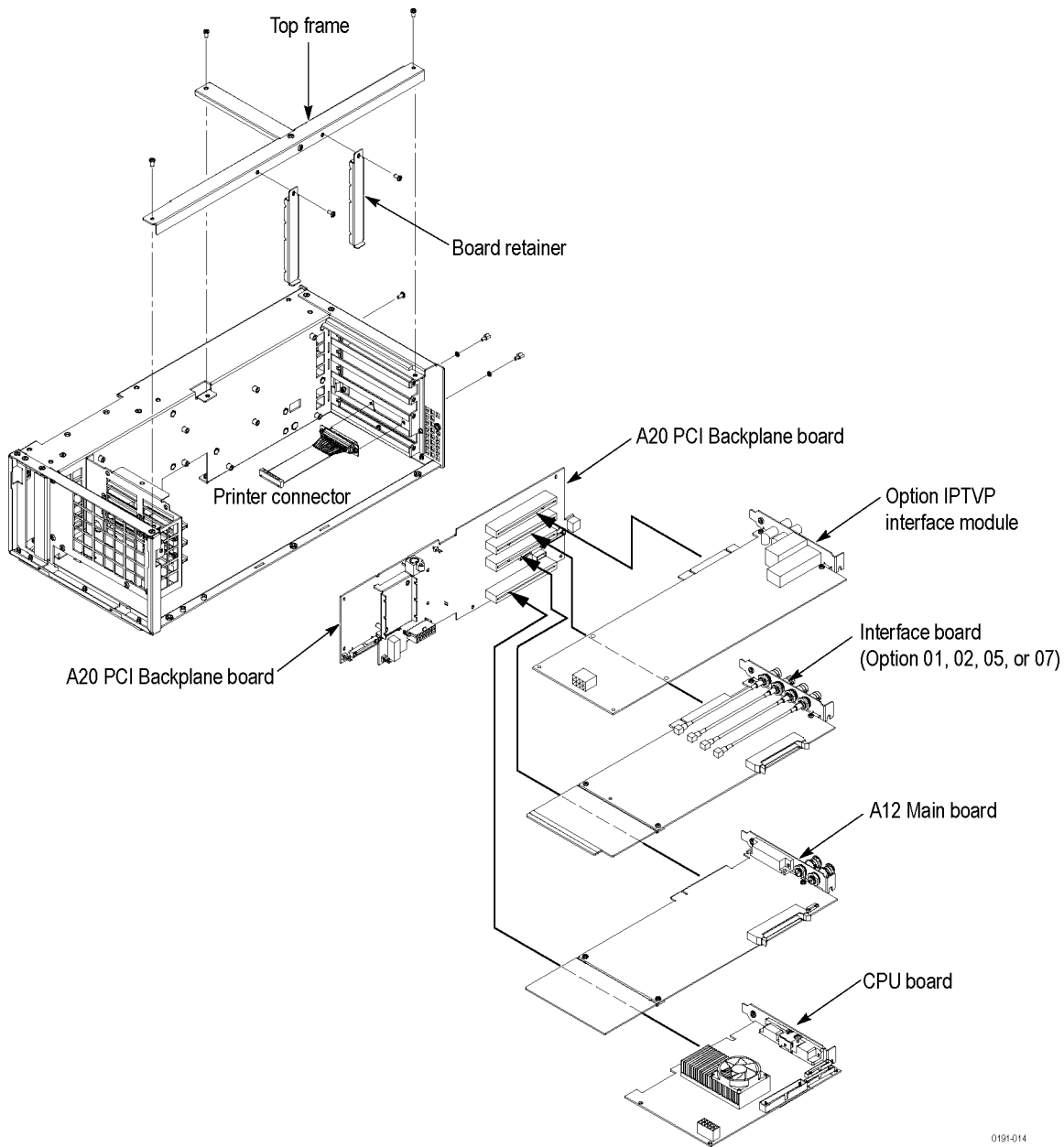

Figure 3-8: Disassembly of front-panel assembly

## Procedure for Board Modules

### Top Frame and Board Retainers

1. Assemble the equipment and locate the module to be removed:
  - You need a screwdriver with a T10 TORX tip.
2. Orient the instrument: Set the MTS400P so that its bottom is down on the work surface and its right side is facing you.
3. Remove the board retainers: (See Figure 3-9.)
  - a. Use a screwdriver with a T10 TORX tip to remove the two screws securing the board retainers to the chassis.
  - b. Lift the retainers away from the chassis.



0191-014

**Figure 3-9: Interface modules, A12 Main board, CPU board, and A20 PCI Backplane board removal**

4. Remove the top frame: (See Figure 3-9.)
  - a. Use a screwdriver with a T10 TORX tip to remove the three screws securing the top frame to the chassis.
  - b. Lift the top frame away from the chassis.

**Option IPTVP (GbE)**

If an Option IPTVP module (GbE) is installed, follow this process to remove it. You must have already removed the cabinet, right side cover, and the board retainers.

1. Assemble the equipment and locate the module to be removed:
  - a. You need a screwdriver with a T10 TORX tip.
  - b. Locate the interface module in the locator diagram *Board modules*. (See Figure 3-3.)
2. Orient the instrument: Set the MTS400P so that its bottom is down on the work surface and its right side is facing you.
3. *Remove the interface module:*
  - a. Disconnect the CIP cable from J10 on the Option module.
  - b. Use a screwdriver with a T10 TORX tip to remove the two screws securing the board bracket to the chassis.
  - c. Grasp the board and slide it out.
4. Reinstallation: Perform step 3 in reverse order to reinstall the Option IPTVP module.

**A170 SMPTE310M/ASI/PSI  
Interface Module**

1. Assemble the equipment and locate the module to be removed:
  - a. You need a screwdriver with a T10 TORX tip.
  - b. Locate the interface module in the locator diagram *Board modules*. (See Figure 3-3.)
2. Orient the instrument: Set the MTS400P so that its bottom is down on the work surface and its right side is facing you.
3. *Remove the interface module:* (See Figure 3-9.)
  - a. Disconnect the cable connecting the option board and the A12 Main board from the A12 Main board.
  - b. Use a screwdriver with a T10 TORX tip to remove the two screws securing the board bracket to the chassis.
  - c. Grasp the board and slide it out.
4. Reinstallation: Perform step 3 in reverse order to reinstall the interface module.

**Installing an SFP Module**

**Installing an SFP Module (GbE Interface Only).** The optional IP Video Gigabit Ethernet (GbE) interface card allows you to remotely monitor and measure the quality of video over copper and optical IP networks. SFP (Small Format Pluggable) modules are available to facilitate different optical wavelengths.



**WARNING.** To avoid exposure to hazardous laser radiation, use only Class 1 lasers as defined in the USA Federal Regulations CDRH 21 CFR 1040 and IEC/EN 60825/A2:2001.

---



**CAUTION.** To prevent static discharge damage, service the product only in a static-free environment. Observe standard handling precautions for static-sensitive devices while installing this module. Always wear a grounded wrist strap, grounded foot strap, and static resistant apparel while installing this module.

---

The following figure shows an SFP module with the optical port plug removed. Use the plug to protect the optical interface when no cable is connected or the module is not in use.

**NOTE.** The optical port plug must be in place when no cable is connected.

---

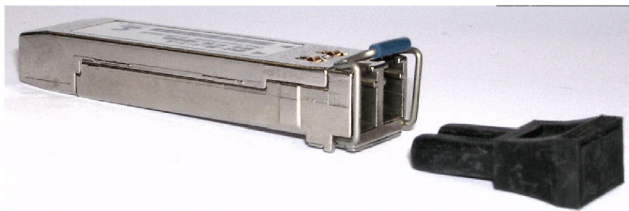

**Installing an SFP Module.** Perform the following steps to install an SFP module into the GbE interface card:



**CAUTION.** To avoid damage to the SFP module, remove power from the MTS400P instrument before removing or inserting an SFP module.

---

1. Disconnect the power cord from the instrument.
2. Insert the SFP module into the connector labeled SFP 1000 on the rear panel of the GbE interface card. When pushed in fully, the module latches into position.
3. Remove the optical port plug and insert the optical fiber cable into the SFP module as shown in the following figure. (See Figure 3-10.) When pushed in fully, the cable connector latches into position. Retain the optical port plug for later use when you need to remove the SFP module from the instrument.
4. Reconnect the power cord to the instrument.

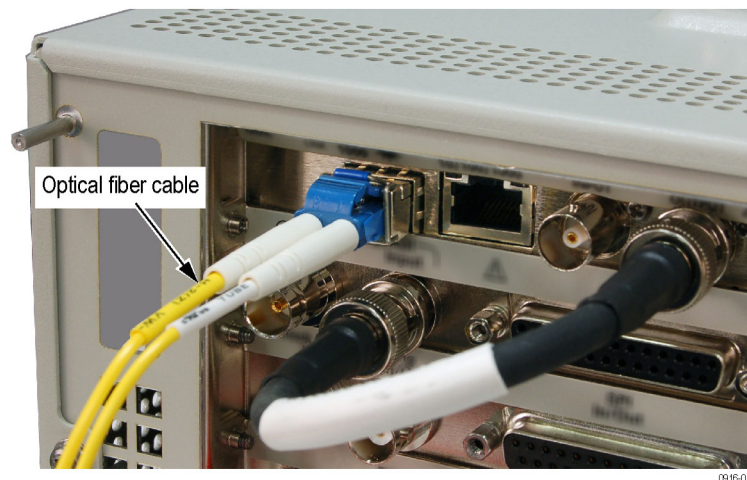

**Figure 3-10: Attaching an optical cable to the SFP module.**

**Removing an SFP Module.** Perform the following steps to remove an SFP module from the GbE interface card:

1. Disconnect the power cord from the instrument.
2. Press the top of the SFP module connector to unlatch the optical fiber cable, and then disconnect and withdraw the cable from the SFP module.
3. Flip down the SFP module retaining latch, and then remove the module from the instrument as shown in the following figure. (See Figure 3-11.)

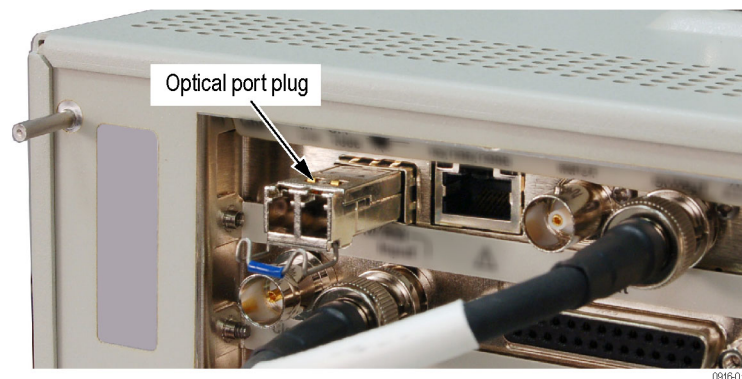

**Figure 3-11: Removing the SFP module.**

4. Install an optical port plug into the removed SFP module to protect the optical port interface.
5. Reconnect the power cord to the instrument.

## A12 Main Board

---

**NOTE.** *If you replace the A12 Main board with a new one, you must run the Instrument ID setup to write instrument-specific information onto the new board. See the following Replacing a defective A12 Main board procedure.*

---

1. Assemble the equipment and locate the module to be removed:
  - a. You need a screwdriver with a T10 TORX tip.
  - b. Locate the A12 Main board in the locator diagram *Board modules*. (See Figure 3-3.)
2. Orient the instrument: Set the MTS400P so that its bottom is down on the work surface and its right side is facing you.
3. *Remove the A12 Main board:* (See Figure 3-9.)
  - a. If an optional interface module is installed, disconnect the cable from the interface module.
  - b. Use a screwdriver with a T10 TORX tip to remove the two screws securing the board bracket to the chassis.
  - c. Grasp the board and slide it out.
4. Reinstallation: Perform step 3 in reverse order to reinstall the A12 Main board.

## Replacing a Defective A12 Main Board

If you are replacing a defective A12 Main board you must perform the following procedure after you reassemble the instrument and power it on. This restores information that had been saved by the old board.

1. Replace the defective A12 Main board, as described above.
2. Reassemble the MTS400P MPEG Player and Recorder, and turn it on.
3. Go to **C:\Program Files\Tektronix\MpegPlayer** and select **ID.exe** file.
4. Run the **ID.exe** file. The Instrument ID Setup dialog box appears.
5. Select the Instrument type in the Instrument ID Setup dialog box, as shown below. (See Figure 3-12.)
6. Click the update button.



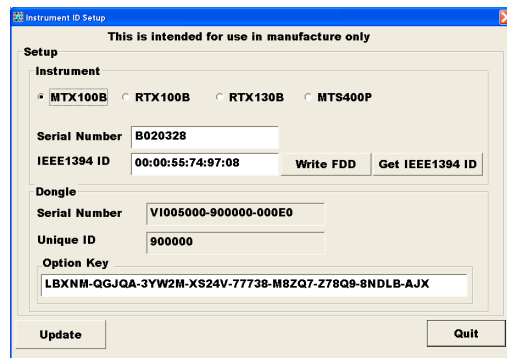

Figure 3-12: Instrument ID Setup dialog

---

**NOTE.** You need to run the *ID.exe* file once you install the new A 12 card to restore the information that was saved in the old A12 broken card.

---

## CPU Board

1. Assemble the equipment and locate the module to be removed:
  - a. You need a screwdriver with a T10 TORX tip.
  - b. Locate the CPU board in the locator diagram *Board modules*. (See Figure 3-3.)
2. Orient the instrument: Set the MTS400P so that its bottom is down on the work surface and its right side is facing you.
3. *Remove the CPU board:* (See Figure 3-9.)
  - a. Disconnect these cables:
    - The cable from the hard disk drive at CN1.
    - The cable from the Printer connector at CN3.
    - The cables from the A20 PCI Backplane board at CN5, CN6, CN9, and CN14.
    - The cable from the Front-Panel Processor board at CN7.
  - b. Use a screwdriver with a T10 TORX tip to remove the two screws securing the board bracket to the chassis.
  - c. Grasp the board and slide it out.
4. Reinstallation: Perform step 3 in reverse order to reinstall the CPU board.

---

**NOTE.** *If you replace the A20 PCI Backplane board, you must return the instrument to your local Tektronix Service Center to have instrument-specific information installed on the new board.*

---

### **A20 PCI Backplane Board**

1. Assemble the equipment and locate the module to be removed:
  - a. You need a screwdriver with a T10 TORX tip.
  - b. Locate the A20 PCI Backplane board in the locator diagram *Board modules*. (See Figure 3-3.)
2. Orient the instrument: Set the MTS400P so that its bottom is down on the work surface and its right side is facing you.
3. Remove the A20 PCI Backplane board: (See Figure 3-9.)
  - a. Remove the interface module (if needed). (See page 3-21, *Option IPTVP (GbE)*.)
  - b. Remove the A12 Main board. (See page 3-24, *A12 Main Board*.)
  - c. Remove the CPU board. (See page 3-25, *CPU Board*.)
  - d. Disconnect these cables:
    - The cable from the A40 AC Distributor board at J220.
    - The cable from the 12 V main power supply at J160 and J170.
    - The cable from the external fan at J190.
    - The cable from the internal fan at J180.
    - The cables from the Front-Panel Processor board at J240.
    - The cable from the hard disk drive.
  - e. Use a screwdriver with a T10 TORX tip to remove the ten screws securing the A20 PCI Backplane board to the chassis.
  - f. Lift the board up and away from the chassis.
4. Reinstallation: Perform step 3 in reverse order to reinstall the A20 PCI Backplane board.

**Printer Connector**

1. Assemble the equipment and locate the modules to be removed:
  - a. You need a 1/4 inch nut driver.
  - b. Locate the connector in the locator diagram *Board modules*. (See Figure 3-3.)
2. Orient the instrument: Set the MTS400P so that its bottom is down on the work surface and its rear is facing you.
3. Remove the Printer connector: (See Figure 3-9.)
  - a. Remove the parallel dongle.
  - b. Remove the interface module (if needed). (See page 3-21, *Option IPTVP (GbE)*.)
  - c. Remove the A12 Main board. (See page 3-24, *A12 Main Board*.)
  - d. Disconnect the cable from CN3 on the CPU board.
  - e. Use a 1/4 inch nut driver to unscrew the two hex-headed mounting posts securing the connector to the chassis.
  - f. Pull the connector away from the chassis.
4. *Reinstallation*: Torque the dongle screws to 5 inch lbs. Perform step 3 in reverse order to reinstall the Printer connector.

## Procedure for Internal Modules

Perform the *Access Procedure* before doing any procedure in this group. The procedures are:

- *Hard disk drive*
- *Internal and external fans*
- *12 V main power supply*
- *A40 AC Distributor board*
- *RFI filter*

### Hard Disk Drive

1. Assemble the equipment and locate the module to be removed:
  - a. You need a screwdriver with a T10 TORX tip.
  - b. Locate the hard disk drive in the locator diagram *Internal modules*. (See Figure 3-4.)
2. *Orient the instrument*: Set the MTS400P so its bottom is down on the work surface and its left side is facing you.
3. *Remove the hard disk drive*: (See Figure 3-13.)
  - a. Disconnect two cables from the hard disk drive.
  - b. Use a screwdriver with a T10 TORX tip to remove the two screws securing the hard disk drive retainer to the chassis.
  - c. Grasp the hard disk drive with the plate, and pull it gently away from the chassis.
  - d. Remove the two screws securing the plate to the hard disk drive.
4. Reinstallation: Perform step 3 in reverse order to reinstall the hard disk drive.

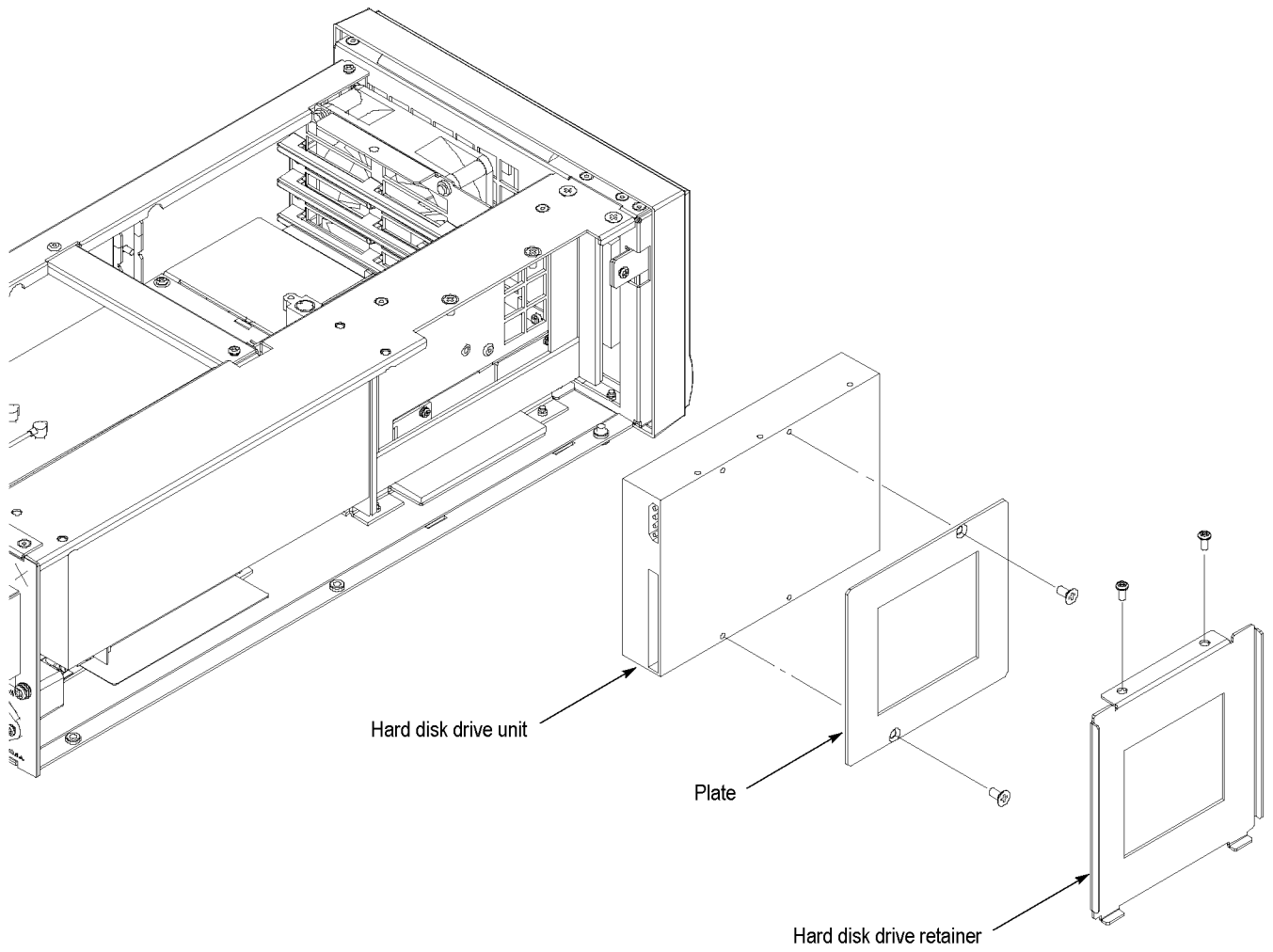

Figure 3-13: Hard disk drive removal

### Internal and External Fans

1. Assemble the equipment and locate the module to be removed:
  - a. You need a screwdriver with a T10 TORX tip.
  - b. Locate the fans in the locator diagram *Internal modules*. (See Figure 3-4.)
2. Orient the instrument: Set the MTS400P so that its bottom is down on the work surface and its front is facing you.
3. Remove the internal fan: (See Figure 3-14.)
  - a. Disconnect the cable from J180 on the A20 PCI Backplane board.
  - b. Remove the two rivets securing the fan to the chassis.
  - c. Lift the fan up out of the chassis.
4. Reinstallation: Perform step 3 in reverse order to reinstall the internal fan.
5. Remove the external fan: (See Figure 3-14.)
  - a. Set the MTS400P so its bottom is down on the work surface and its rear is facing you.
  - b. Disconnect the cable from J190 on the A20 PCI Backplane board.
  - c. Use a screwdriver with a T10 TORX tip to remove the four screws securing the fan and fan cover to the chassis.
6. *Reinstallation:* Perform step 5 in reverse order to reinstall the external fan.

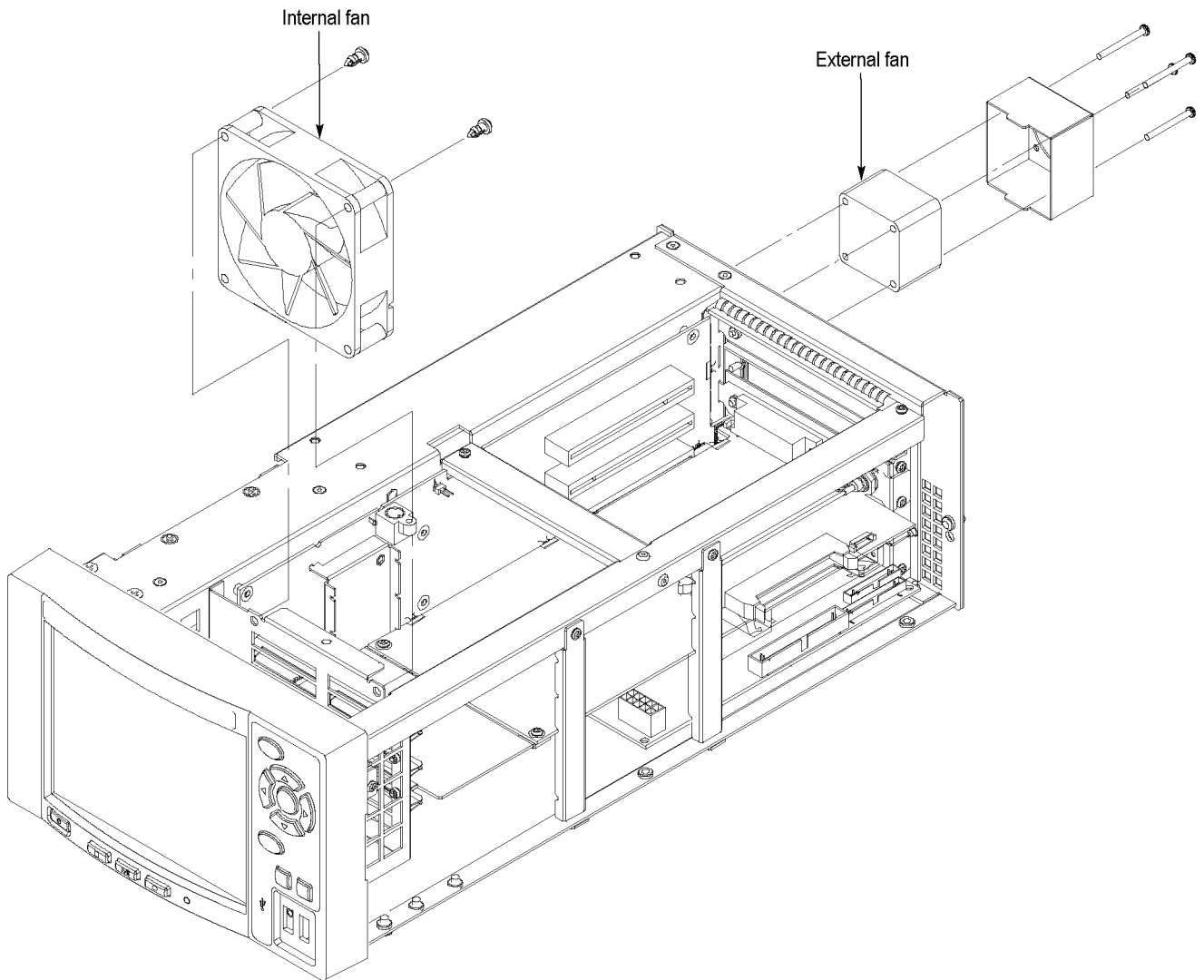

Figure 3-14: Internal and external fan removal

### 12 V Main Power Supply

1. Assemble the equipment and locate the module to be removed:
  - a. You need a screwdriver with a T10 TORX tip.
  - b. Locate the 12 V main power supply in the locator diagram *Internal modules*. (See Figure 3-4.)
2. Orient the instrument: Set the MTS400P so that its bottom is down on the work surface and its left side is facing you.
3. Remove the 12 V main power supply: (See Figure 3-15.)
  - a. Disconnect the cables from CN1, CN2, CN3, and CN4.
  - b. Use a screwdriver with a T10 TORX tip to remove the four screws securing the 12 V main power supply to the chassis.
  - c. Lift the power supply away from the chassis.
4. Reinstallation: Perform step 3 in reverse order to reinstall the 12 V main power supply.

### A40 AC Distributor Board

1. Assemble the equipment and locate the module to be removed:
  - a. You need a screwdriver with a T10 TORX tip.
  - b. Locate the A40 AC Distributor board in the locator diagram *Internal modules*. (See Figure 3-4.)
2. Orient the instrument: Set the MTS400P so that its bottom is down on the work surface and its left side is facing you.
3. Remove the A40 AC Distributor board: (See Figure 3-15.)
  - a. Disconnect the cables from J100, J110, and J120.
  - b. Use a screwdriver with a T10 TORX tip to remove the three screws securing the A40 AC Distributor board to the chassis.
  - c. Lift the board away from the chassis.
4. *Reinstallation:* Perform step 3 in reverse order to reinstall the A40 AC Distributor board.



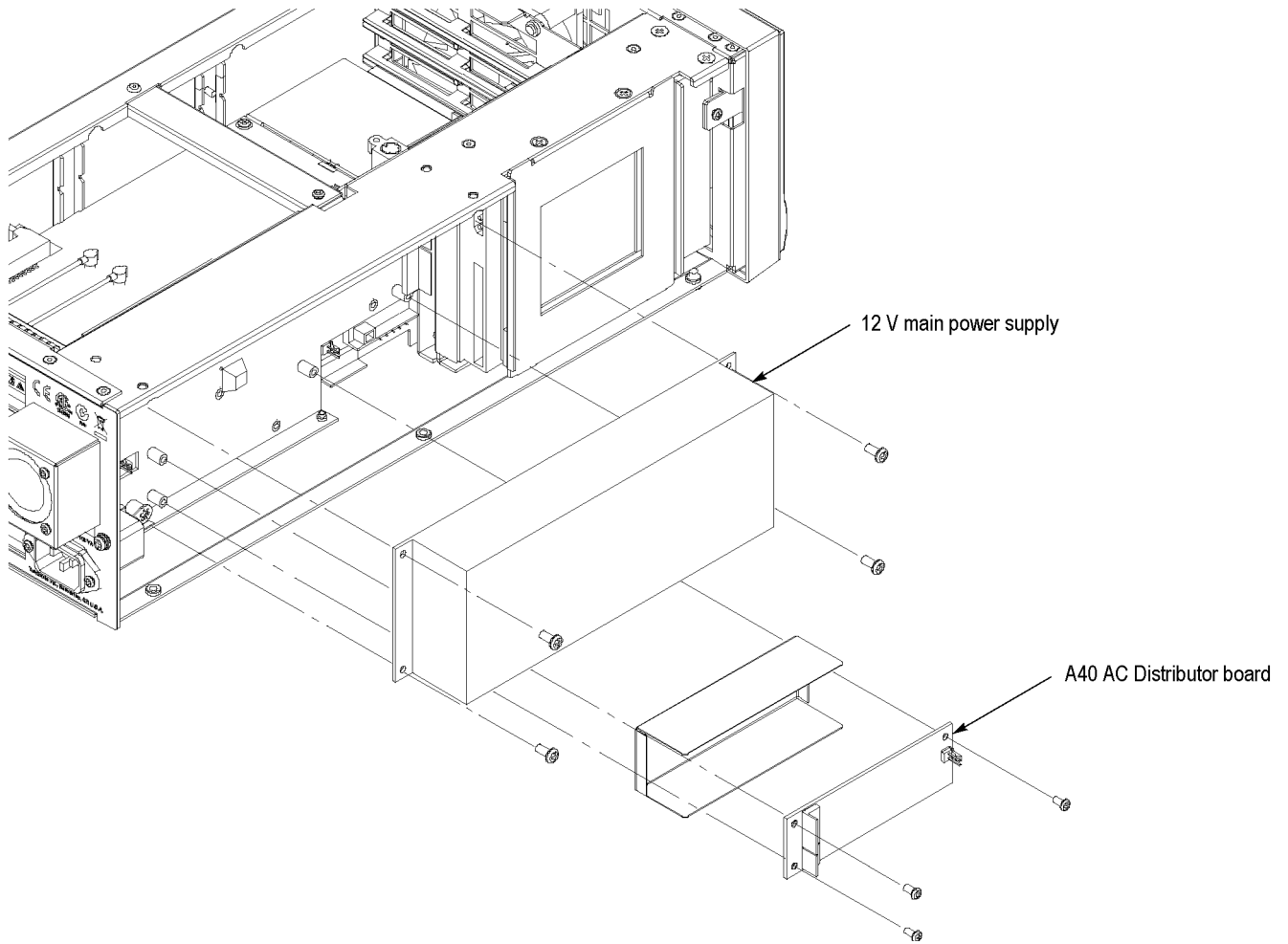

Figure 3-15: 12 V main power supply and A40 AC Distributor board removal

- RFI Filter**
- 1.** Assemble the equipment and locate the module to be removed:
    - a.** You need a screwdriver handle, a T10 TORX tip, and a T15 TORX tip.
    - b.** Locate the RFI filter in the locator diagram *Internal modules*. (See Figure 3-4.)
  - 2.** Orient the instrument: Set the MTS400P so that its bottom is down on the work surface and its rear is facing you.
  - 3.** Remove the RFI filter: (See Figure 3-16.)
    - a.** Disconnect the two cables from the RFI filter.
    - b.** Use a screwdriver with a T15 TORX tip to remove the screw securing the ground lead to the chassis.
    - c.** Use a screwdriver with a T10 TORX tip to remove the two screws securing the RFI filter to the chassis.
    - d.** Pull the RFI filter away from the chassis.
  - 4.** Reinstallation: Perform step 3 in reverse order to reinstall the RFI filter.

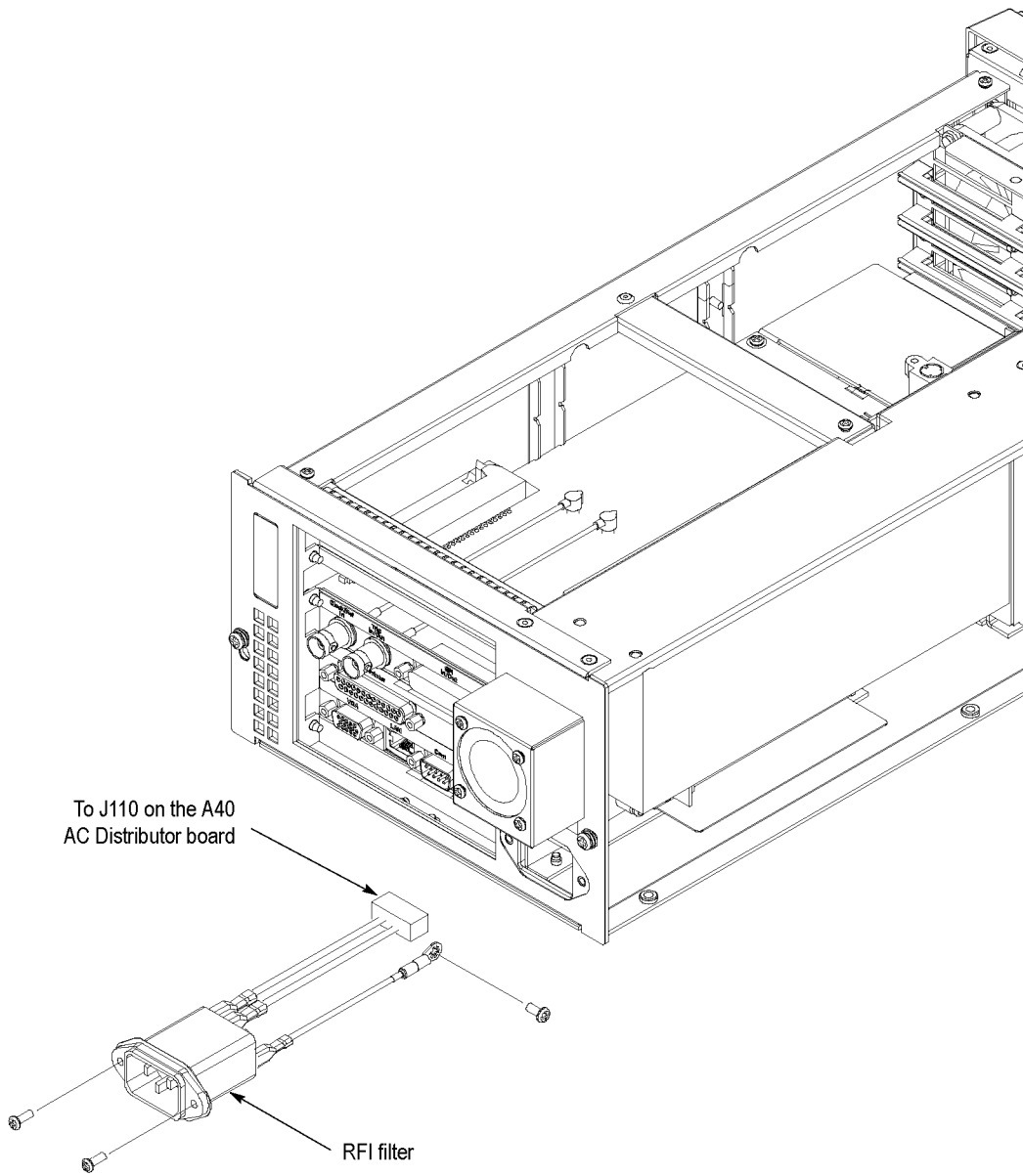

Figure 3-16: RFI filter removal

# Verifying the BIOS Configuration

This section provides information needed to verify or set the BIOS configuration.

## Procedure



**CAUTION.** *It is very important to follow this procedure exactly or the instrument will not operate correctly.*

Perform the following procedure to set the BIOS configuration:

1. Connect the USB keyboard to the USB connector on the front panel.
2. Power on the instrument, and then press the **Del** key immediately. The **AwardBIOS CMOS Setup Utility screen** appears.
3. Set the BIOS configuration as follows. Use the arrow keys to highlight each item, and then press the **Enter** key to select it.

BIOS Configuration		Setting
Under Standard CMOS Features	Drive A	None
Advanced BIOS Features	First Boot Device	HDD-0
	Second Boot Device	USB-CDROM
	Third Boot Device	USB-HDD
Advanced Chipset Features	Boot Display	CRT+LFP
	Panel Number	1024X768
Integrated Peripherals	Super IO Device	Onboard FDC Controller: Disabled
	Onboard Serial Port 2	Disabled (Standard) 2F8 (Option IPTVP Only)
	Onboard Serial Port 4	Disabled
PC Health Status	CPU Warning Temperature	Disabled
	Shutdown Temperature	Disabled

4. Use the arrow keys to select **Save & Exit Setup**, and then press the **Enter** key. The Save to CMOS and Exit (Y/N)? message appears.
5. Enter **Y**, and press the **Enter** key.

### Option IPTVP (GbE)

If Option IPTVP is installed, Onboard Serial Port 2 (COM2) must be enabled. If it is not, follow these steps to enable it:

1. Connect the USB keyboard to the USB connector on the front panel.
2. Power on the instrument, and then press the **Del** key immediately. The **AwardBIOS CMOS Setup Utility screen** appears.

3. Select Integrated Peripheral, and then set the Onboard Serial Port 2 setting to 2F8 to enable COM2, as shown below.

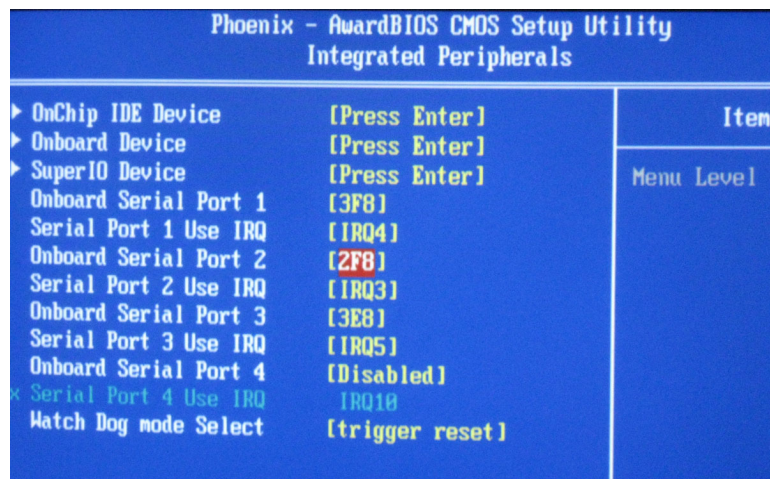

Phoenix - AwardBIOS CMOS Setup Utility		
Integrated Peripherals		
▶ OnChip IDE Device	[Press Enter]	Item
▶ Onboard Device	[Press Enter]	
▶ SuperIO Device	[Press Enter]	Menu Level
Onboard Serial Port 1	[3F8]	
Serial Port 1 Use IRQ	[IRQ4]	
Onboard Serial Port 2	<b>[2F8]</b>	
Serial Port 2 Use IRQ	[IRQ3]	
Onboard Serial Port 3	[3E8]	
Serial Port 3 Use IRQ	[IRQ5]	
Onboard Serial Port 4	[Disabled]	
* Serial Port 4 Use IRQ	IRQ10	
Watch Dog mode Select	[trigger reset]	

4. Use the arrow keys to select **Save & Exit Setup**, and then press the **Enter** key. The Save to CMOS and Exit (Y/N)? message appears.
5. Enter **Y**, and press the **Enter** key.

# Troubleshooting

This subsection contains information about troubleshooting trees designed to isolate faulty modules in the MTS400P.

## **Troubleshooting Trees**

The following figures show the troubleshooting procedure for the MTS400P. Refer to the *Cables* illustration to locate the cables referenced in these troubleshooting trees. (See Figure 5-5 on page 5-13.)

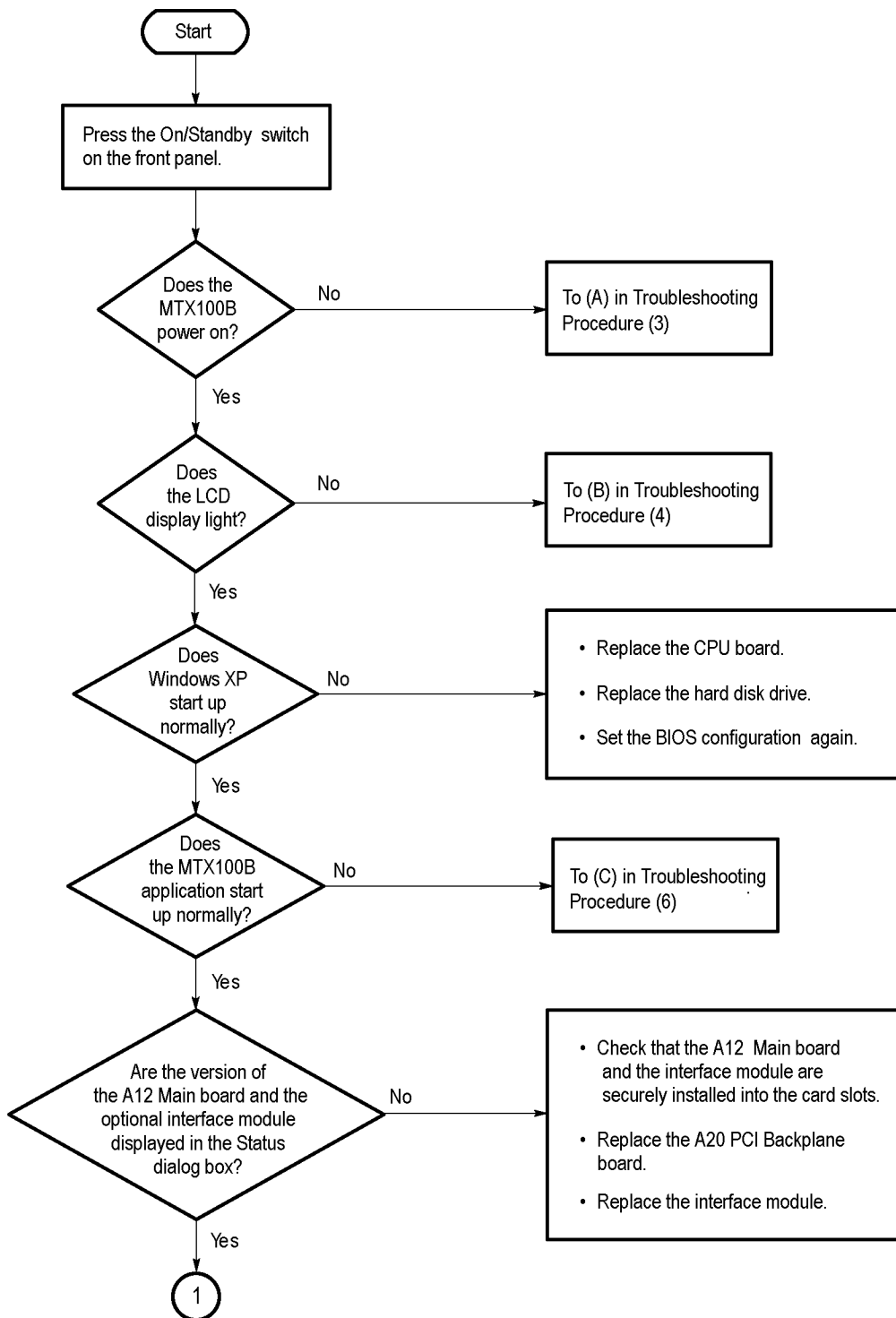

Figure 3-17: Troubleshooting procedure (1)

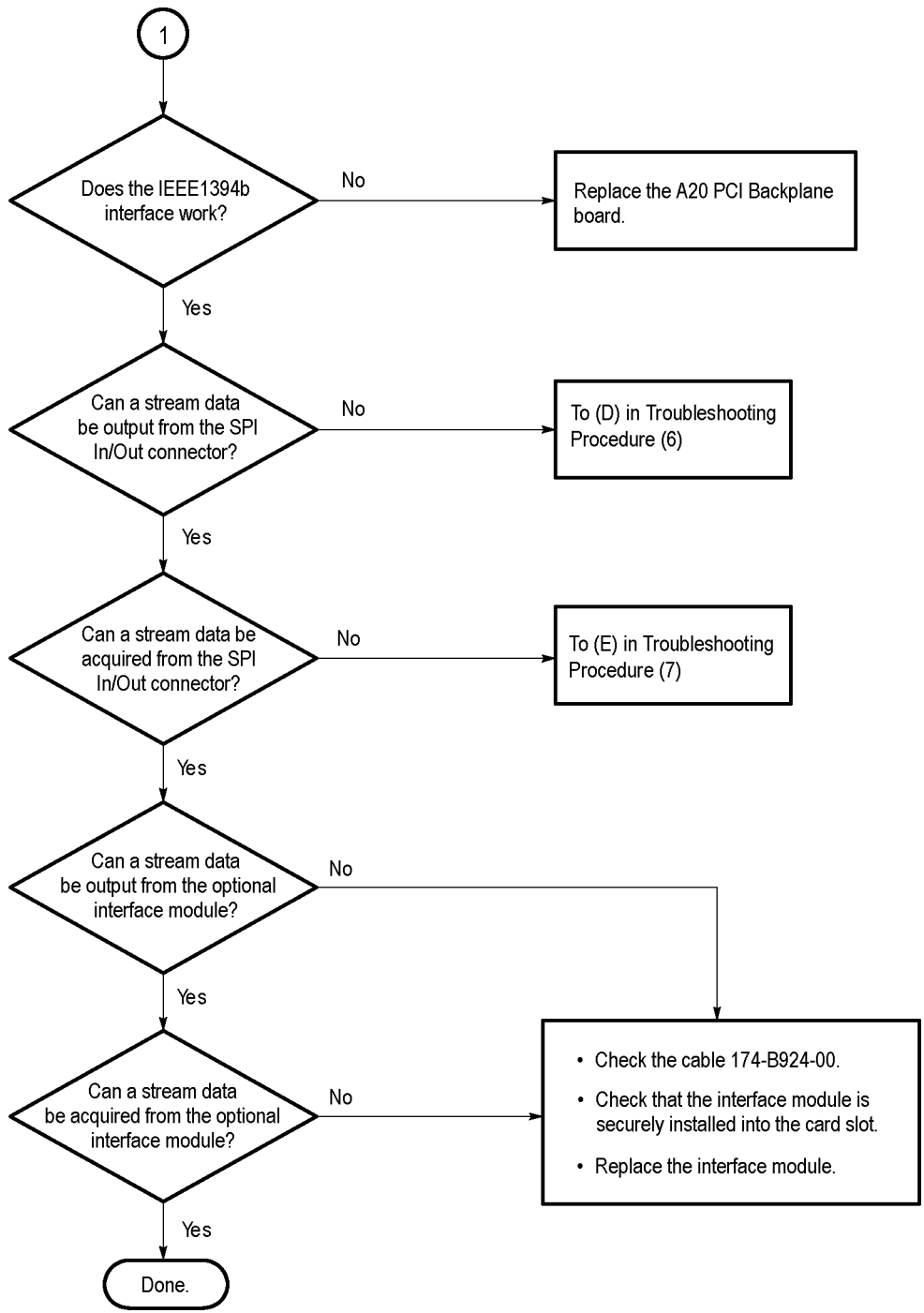

Figure 3-18: Troubleshooting procedure (2)



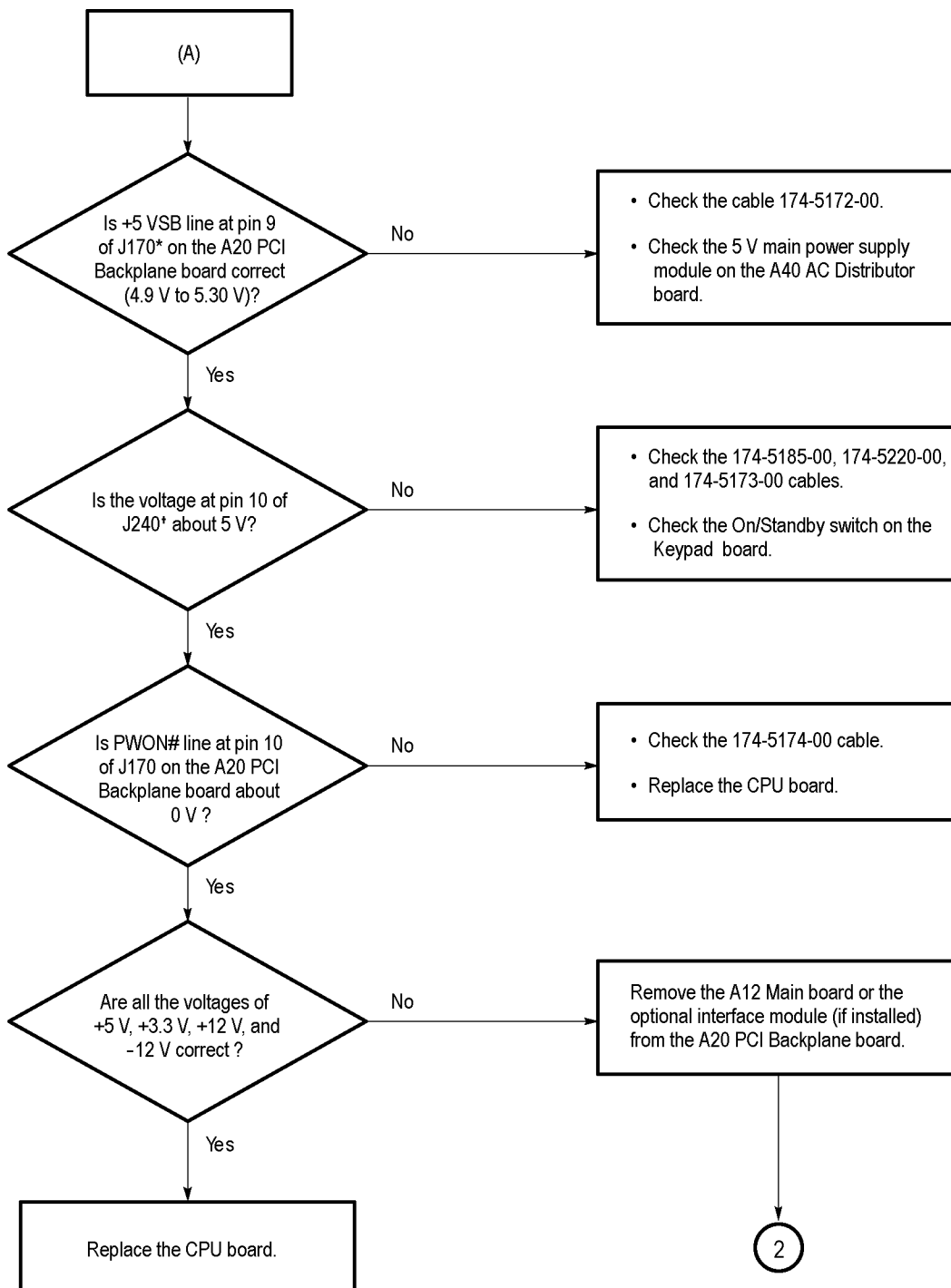

Figure 3-19: Troubleshooting procedure (3)

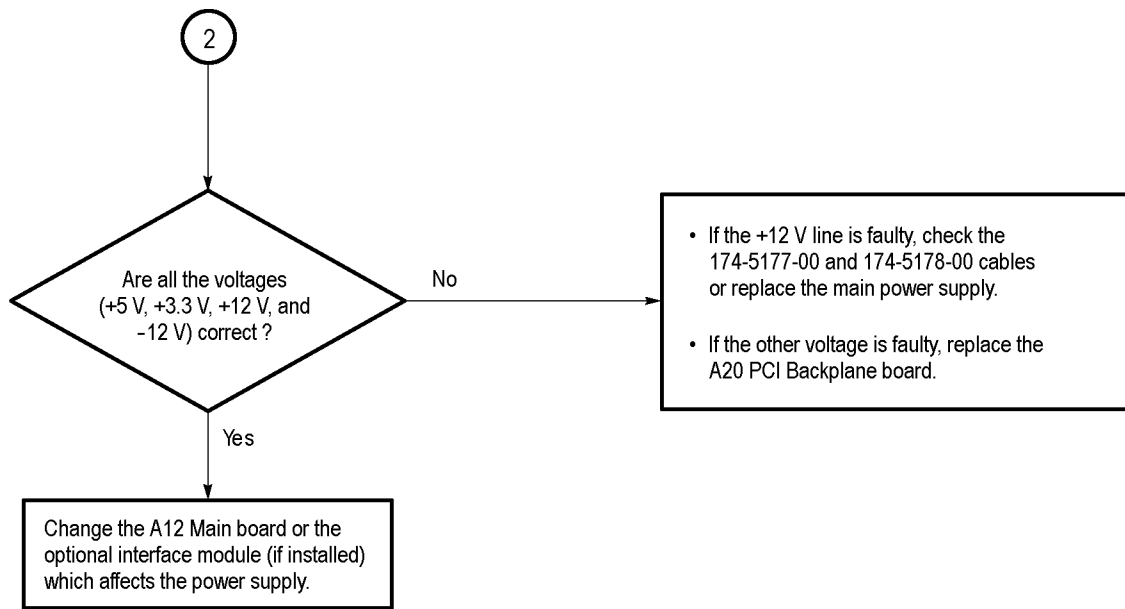

Figure 3-20: Troubleshooting procedure (4)

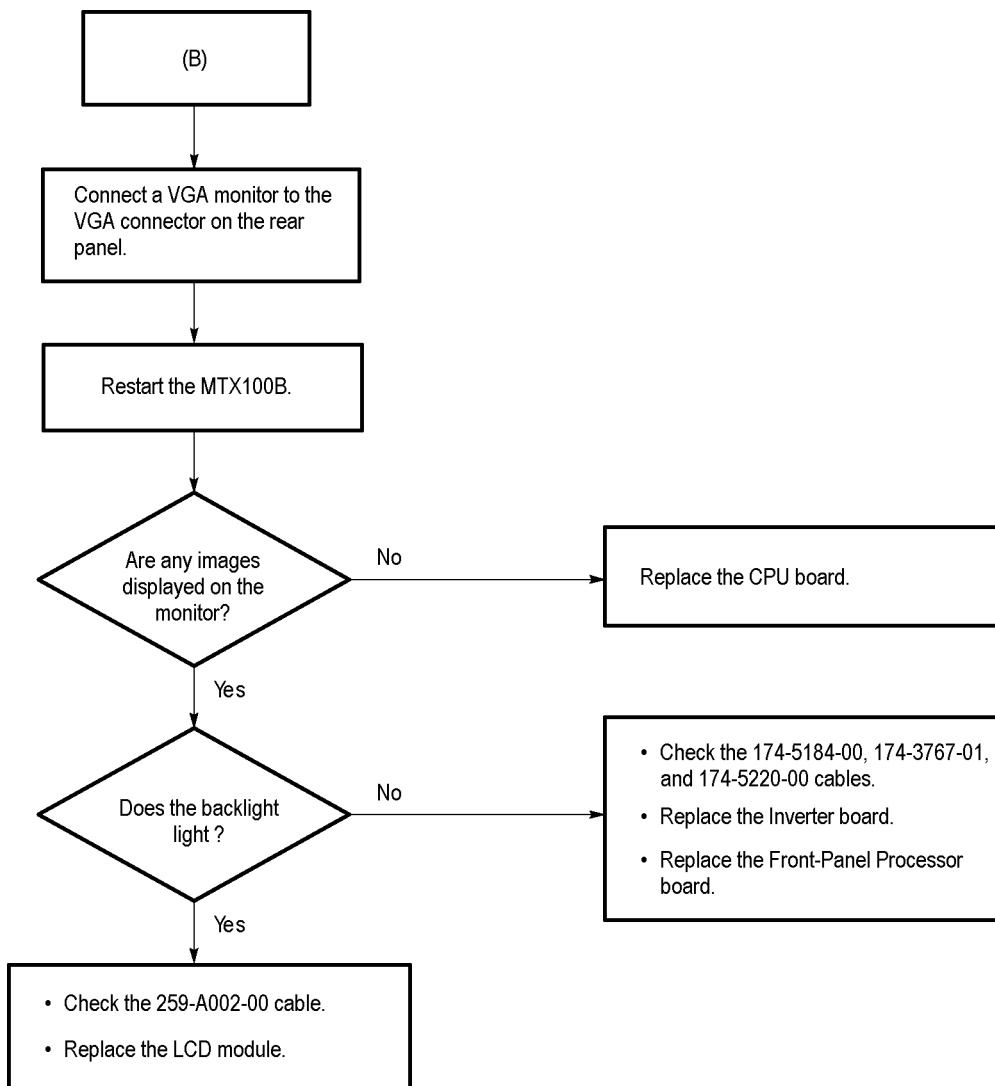

Figure 3-21: Troubleshooting procedure (5)

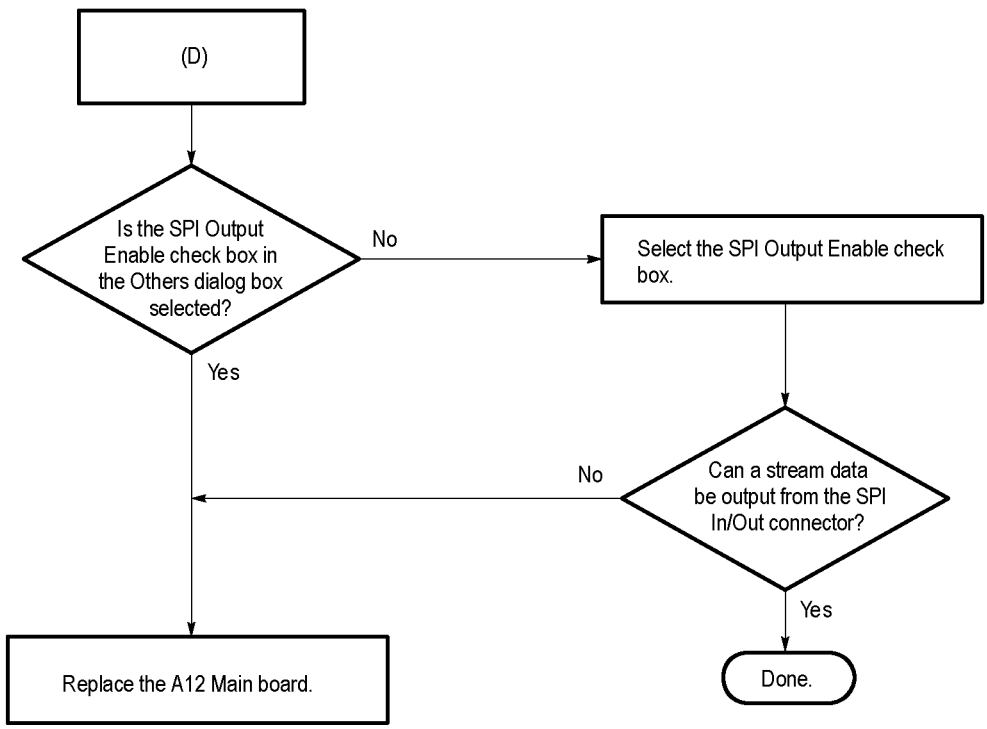
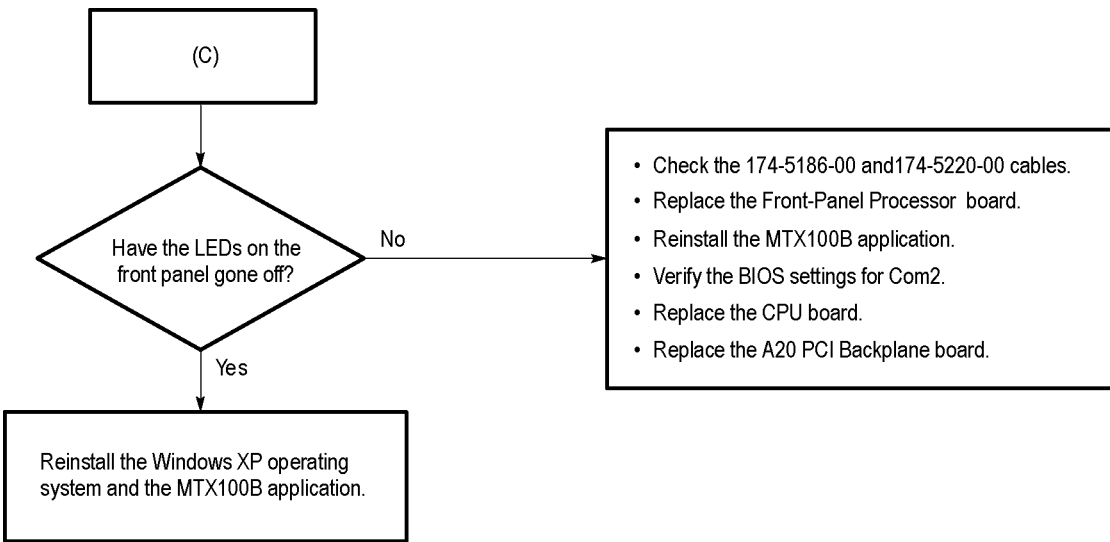

Figure 3-22: Troubleshooting procedure (6)

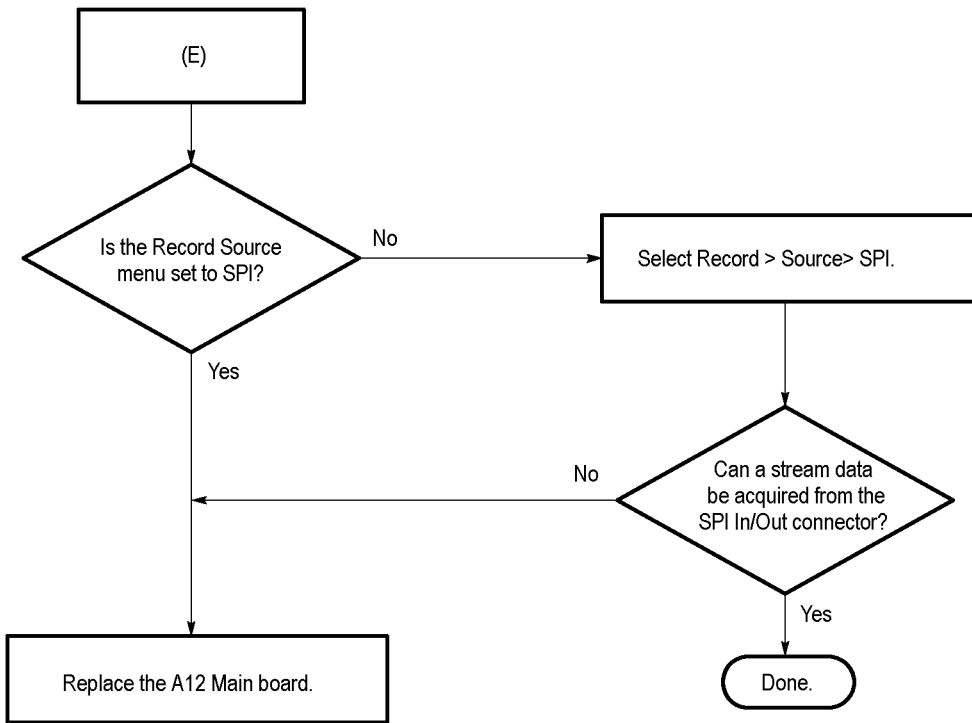

Figure 3-23: Troubleshooting procedure (7)



# System Software Recovery

If the MTS400P does not boot up or is corrupted, you can recover the system software by using this recovery procedure.



---

**CAUTION.** *Running the recovery procedure overwrites all the contents of the hard disk drive and resets the system to the factory defaults.*

---

## Recovery Procedure

Perform the following procedure to recover the Windows XP and MTS400P application software:

---

**NOTE.** *The recovery process will not restore the application software (V10.1 and above) or the factory installed test streams.*

---

1. Restart your system and press the **F5** key as soon as the BIOS tests are complete. This opens the Acronis True Image tool with the following options:
  - Restore
  - Windows
2. Click **Restore System** > **Yes**. Click **Windows** if you wish to keep your current configuration intact.

The “skipped probe” messages are normal and can be ignored. Acronis is gathering information on your hardware.



---

**CAUTION.** *Do not power off the system once the recovery process is initiated. Cancelling the process will leave your hard disk drive in a partially recovered, unstable state. Immediately after the data is recovered, the system will let you know that the recovery was successful. On selecting OK, the instrument restarts and the Windows XP setup wizard is displayed. You will need to install the latest version of the software that is available for your instrument.*

---

---

**NOTE.** *The software that is already in the instrument must be reinstalled after the Operating System is restored, because the software is no longer available in the system.*

---





---

# Diagrams



---

# Diagrams

This section contains the following diagrams:

- MTS400P block diagram
- MTS400P interconnect diagram

The block diagram shows the modules and functional blocks in the MTS400P. The interconnect diagram shows how the modules in the MTS400P connect together.

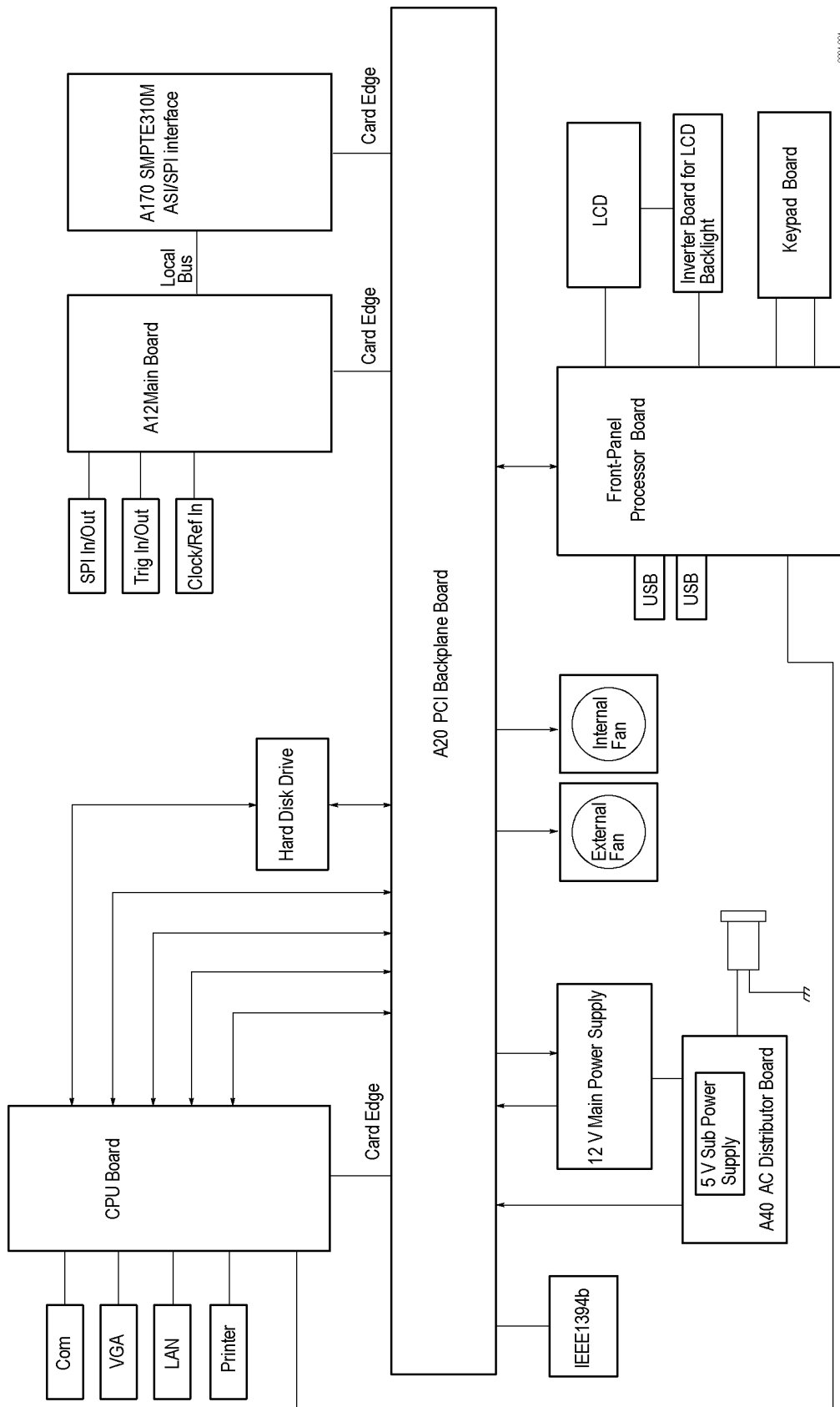

Figure 4-1: MTS400P block diagram

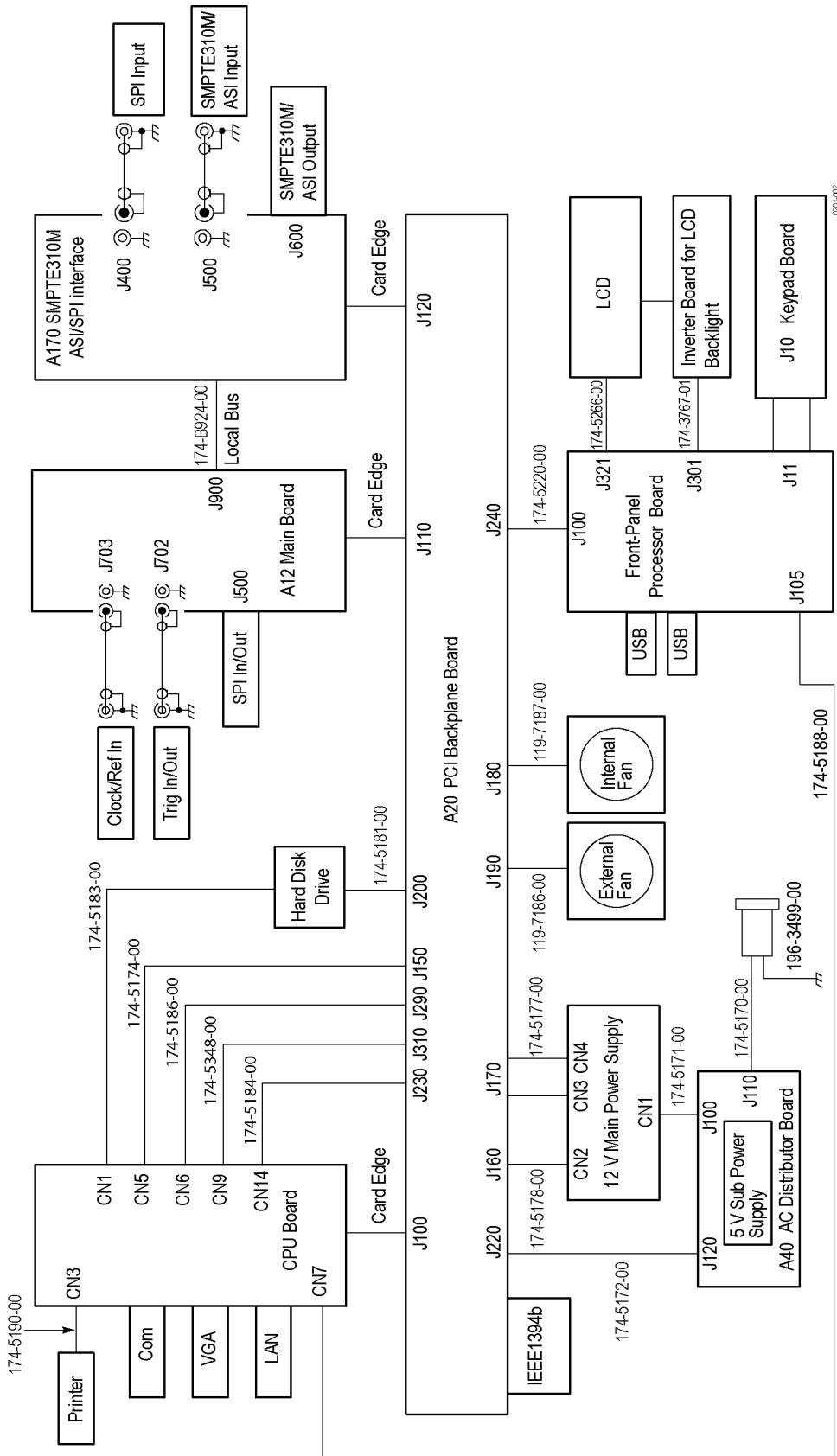

Figure 4-2: MTS400P interconnect diagram

# Optional Module Diagram

This section contains the interconnect diagram of the optional IPTVP interface module.

## GbE (Option IPTVP)

Figure 4-3 shows the Gigabit Ethernet board, and how it connects to the Processor (CPU) board and the A12 Main board.

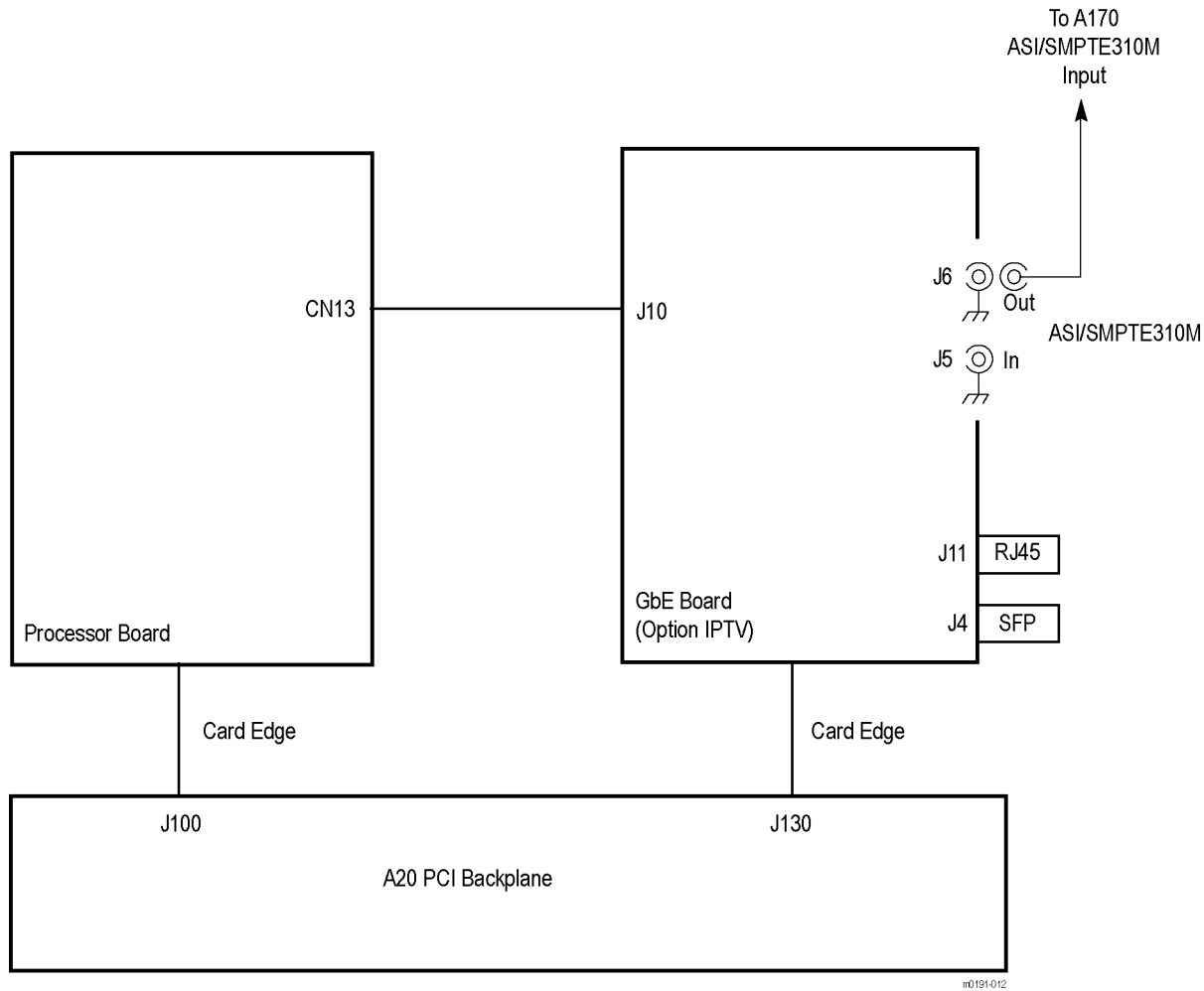

Figure 4-3: Option IPTVP (GbE) module connections

---

# Replaceable Parts List





---

# Replaceable Parts List

This section contains a list of the replaceable modules for the MTS400P. Use this list to identify and order replacement parts.

## Parts Ordering Information

Replacement parts are available through your local Tektronix field office or representative.

Changes to Tektronix products are sometimes made to accommodate improved components as they become available and to give you the benefit of the latest improvements. Therefore, when ordering parts, it is important to include the following information in your order:

- Part number (see Part Number Revision Level below)
- Instrument type or model number
- Instrument serial number
- Instrument modification number, if applicable

If you order a part that has been replaced with a different or improved part, your local Tektronix field office or representative will contact you concerning any change in part number.

Change information, if any, is located at the rear of this manual.

### Part Number Revision Level

Tektronix part numbers contain two digits that show the revision level of the part. For most parts in this manual, you will find the letters XX in place of the revision level number.



When you order parts, Tektronix will provide you with the most current part for your product type, serial number, and modification (if applicable). At the time of your order, Tektronix will determine the part number revision level needed for your product, based on the information you provide.

## **Module Servicing**

Modules can be serviced by selecting one of the following three options. Contact your local Tektronix service center or representative for repair assistance.

**Module exchange.** In some cases you may exchange your module for a remanufactured module. These modules cost significantly less than new modules and meet the same factory specifications. For more information about the module exchange program, call 1-800-833-9200. Outside North America, contact a Tektronix sales office or distributor; see the Tektronix Web site for a list of offices: [www.tektronix.com](http://www.tektronix.com)

**Module repair and return.** You may ship your module to us for repair, after which we will return it to you.

**New modules.** You may purchase replacement modules in the same way as other replacement parts.

## Using the Replaceable Parts List

This section contains a list of the mechanical and/or electrical components that are replaceable for the MTS400P. Use this list to identify and order replacement parts. The following table describes each column in the parts list.

### Parts list column descriptions

Column	Column name	Description
1	Figure & index number	Items in this section are referenced by figure and index numbers to the exploded view illustrations that follow.
2	Tektronix part number	Use this part number when ordering replacement parts from Tektronix.
3 and 4	Serial number	Column three indicates the serial number at which the part was first effective. Column four indicates the serial number at which the part was discontinued. No entries indicates the part is good for all serial numbers.
5	Qty	This indicates the quantity of parts used.
6	Name & description	An item name is separated from the description by a colon (:). Because of space limitations, an item name may sometimes appear as incomplete. Use the U.S. Federal Catalog handbook H6-1 for further item name identification.

**Abbreviations**      Abbreviations conform to American National Standard ANSI Y1.1-1972.

**Table 5-1: Cabinet and covers**

Fig. & index number	Tektronix part number	Serial no. effective	Serial no. discont'd	Qty	Name & description
5-1					<b>Cabinets and covers</b>
-1	211-0374-00			6	SCREW,MACHINE:6-32X0.25,FLH,100 DEG,STL ZN-CM1,T10 TORX
-2	337-4345-00			1	SHIELD,ELEC:COVER,LEFT,MTX100A,AL
-3	390-1212-01			1	CABINET ASSY;WRAP AROUND HOUSING,0.050 AL,SILVERGRAY,W/FEET&HANDLE, SAFETY CONTROLLED
-4	211-0711-00			2	SCR,ASSEM WSHR;6-32X0.250,PNH,STL,CDPL,T-15 TORX DR,MACHINE,W/SQ CONE WASHER
-5	335-1374-00			1	MARKER,IDENT;LABEL,MKD WARNING TO AVOID ELECTRIC,50.8MMX25.4MM,0.002 POLYESTER(3M 7982),OVER LAMINATE W/0.001 FLEVCON,W/ADHESIVE BACK, SAFETY CONTROLLED
-6	063-3868-00			1	SOFTWARE PKG;MICROSOFT WINDOWS XP PROFESSIONAL,INCLUDES SERVICE PACK 2,1-2 PROCESSOR VERSION;CERTIFICATE OF AUTHENTICITY
-7	337-4346-00			1	SHIELD,ELEC:COVER,RIGHT,MTX100A,AL
-8	211-0374-00			7	SCREW,MACHINE:6-32X0.25,FLH,100 DEG,STL ZN-CM1,T10 TORX

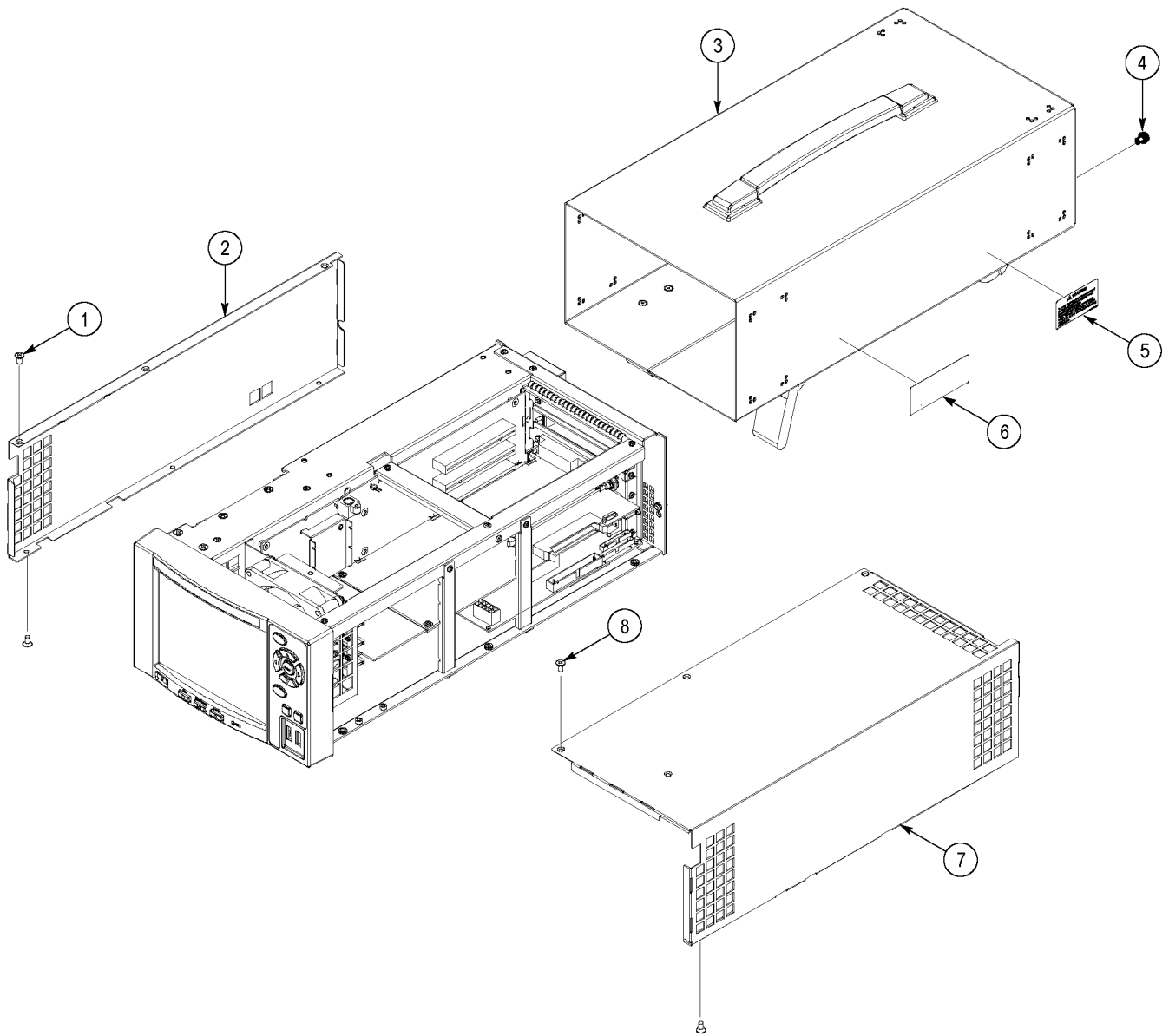

Figure 5-1: Cabinet and covers

**Table 5-2: Internal modules**

Fig. & index number	Tektronix part number	Serial no. effective	Serial no. discont'd	Qty	Name & description
5-2					
-1	211-0734-00			2	SCREW,MACHINE:6-32X0.25,FLH,100 DEG,STL ZN-CM1,T10 TORX
-2	211-0373-00			2	SCREW,MACHINE:4-40X0.25,PNH,STL ZN-CM1,T10 TORX
-3	343-1708-00			1	RETAINER:HARD DISK DRIVE,W/POLYURETHANE,MTX100A,AL
-4	211-0734-00			2	SCREW,MACHINE:6-32X0.25,FLH,100 DEG,STL ZN-CM1,T10 TORX
-5	211-0734-00			2	SCREW,MACHINE:6-32X0.25,FLH,100 DEG,STL ZN-CM1,T10 TORX
-6	386-7460-00			1	PLATE:HDD,AL
-7	650-4862-00			1	HARD DISK DRIVE:160GB,3.5 INCH,7200RPM,ATA-100,MTXB/RTXB PRODUCTS FOR B019999 AND BELOW
-7	650-5181-00			1	SERVICE KIT:SYSPREP ACTIVATED,XP OS,TEST STREAMS INSTALLED, HARD DISK DRIVE REPLACEMENT,MTXB/RTXB PRODUCTS B020000 AND ABOVE
-8	211-0373-00			3	SCREW,MACHINE:4-40X0.25,PNH,STL ZN-CM1,T10 TORX
-9	671-5979-00			1	CIRCUIT BD ASSY:A40,SUB POWER,389-3738-00 WIRED
-10	342-1138-00			1	INSULATOR:CKT BOARD,POLYCARBONATE,A40 BOARD
-11	211-0373-00			4	SCREW,MACHINE:4-40X0.25,PNH,STL ZN-CM1,T10 TORX
-12	119-7147-00			1	POWER SUPPLY:85V-264VAC IN,12VDC 12.5A OUT,LEA150F-12-R,COSEL
-13	211-0711-00			1	SCR,ASSEM WSHR;6-32X0.250,PNH,STL,CDPL,T-15 TORX DR,MACHINE,W/SQ CONE WASHER
-14	196-3496-00			1	LEAD,ELECTRICAL;18 AWG,4.0 L,5-4 SAFETY CONTROLLED
-15	119-6009-00			1	FILTER,RFI;3A,250VAC,0.5,MA,0.15OHM;SAFETY CONTROLLED
-16	211-0372-00			2	SCREW,MACHINE:4-40X0.312,PNH,STL ZN-CM1,T10 TORX
-17	200-4974-00			1	COVER,FAN;REAR,MTX100A,AL
-18	211-1161-00			4	SCREW,MACHINE;4-40X1.500,PNH HEAD,T-10 TORX,ZINC PL
-19	119-7186-00			1	CABLE,ASSEMBLY,4,18AWG,60MM L,HDD POWER(40 SQ FAN)
-20	335-1368-00			1	MARKER, IDENT:MKD CONNECTORS FOR A170
-21	335-1364-00			1	MARKER,IDENT:MKD CONNECTORS FOR A12,POLYCARBONATE
-22	335-1363-00			1	MARKER,IDENT:MKD CONNECTORS PRINTER&IEEE1394B,POLYCARBONATE
-23	335-1362-00			1	MARKER,IDENT:MKD CONNECTORS FOR CPU BD,POLYCARBONATE
-24	335-0133-00			1	MARKER,IDENT;BLANK LABEL FOR MES LINES; THT-37-483-10MONOCHROME DISPLY;TDS300,TDS400 SERIES,SAFETY COTROLLED
-25	441-2404-00			1	CHASSIS,ASSY;MAIN,MTX100A,AL
-26	210-0164-000			2	RIVET,SOLID;0.163 ODX0.415 L,PANEL RANGE HEAD STYLE,NYLON
-27	119-7187-00			1	FAN 119569400 W/CABLE 18CM L(92 SQ FAN)

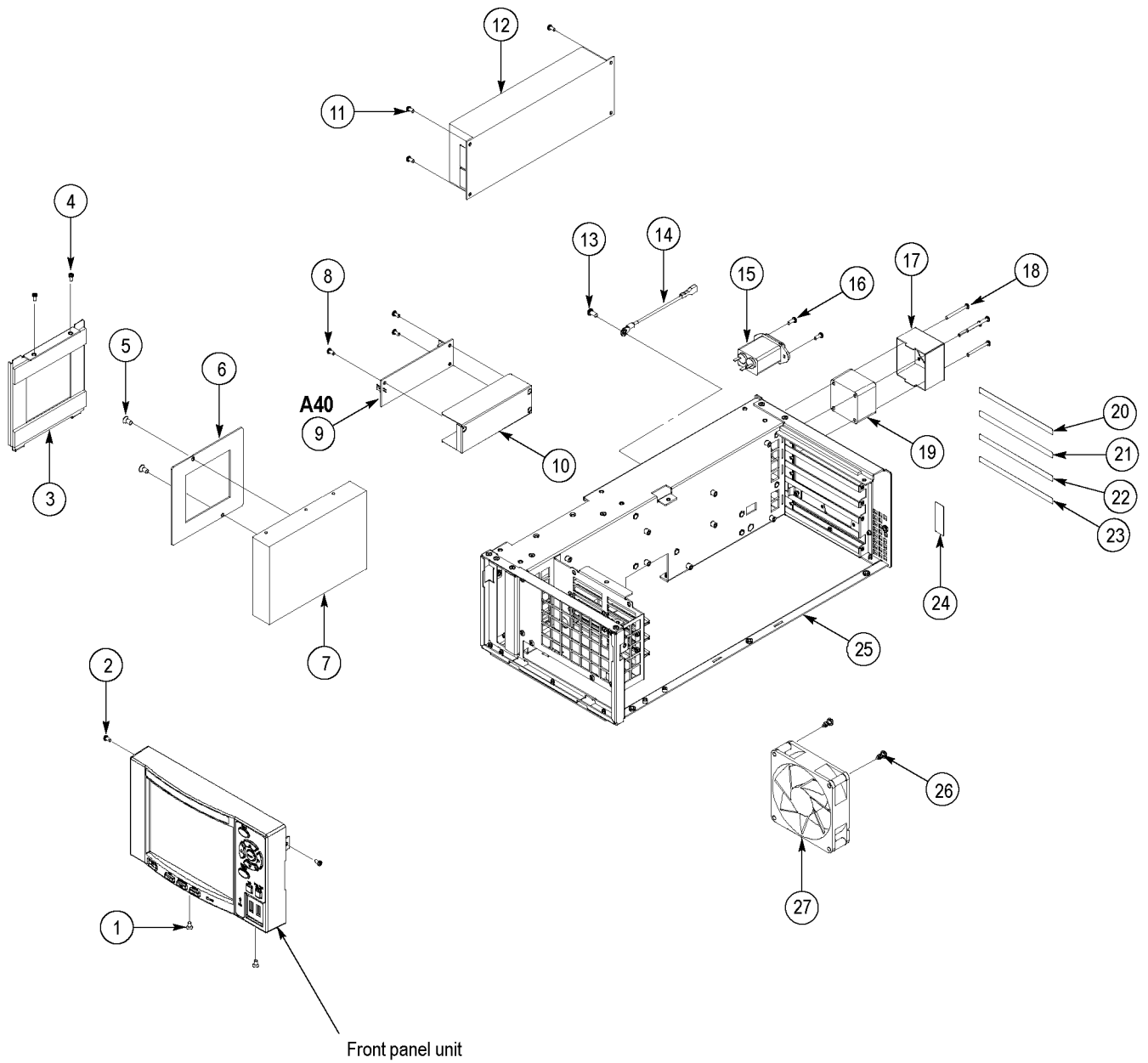
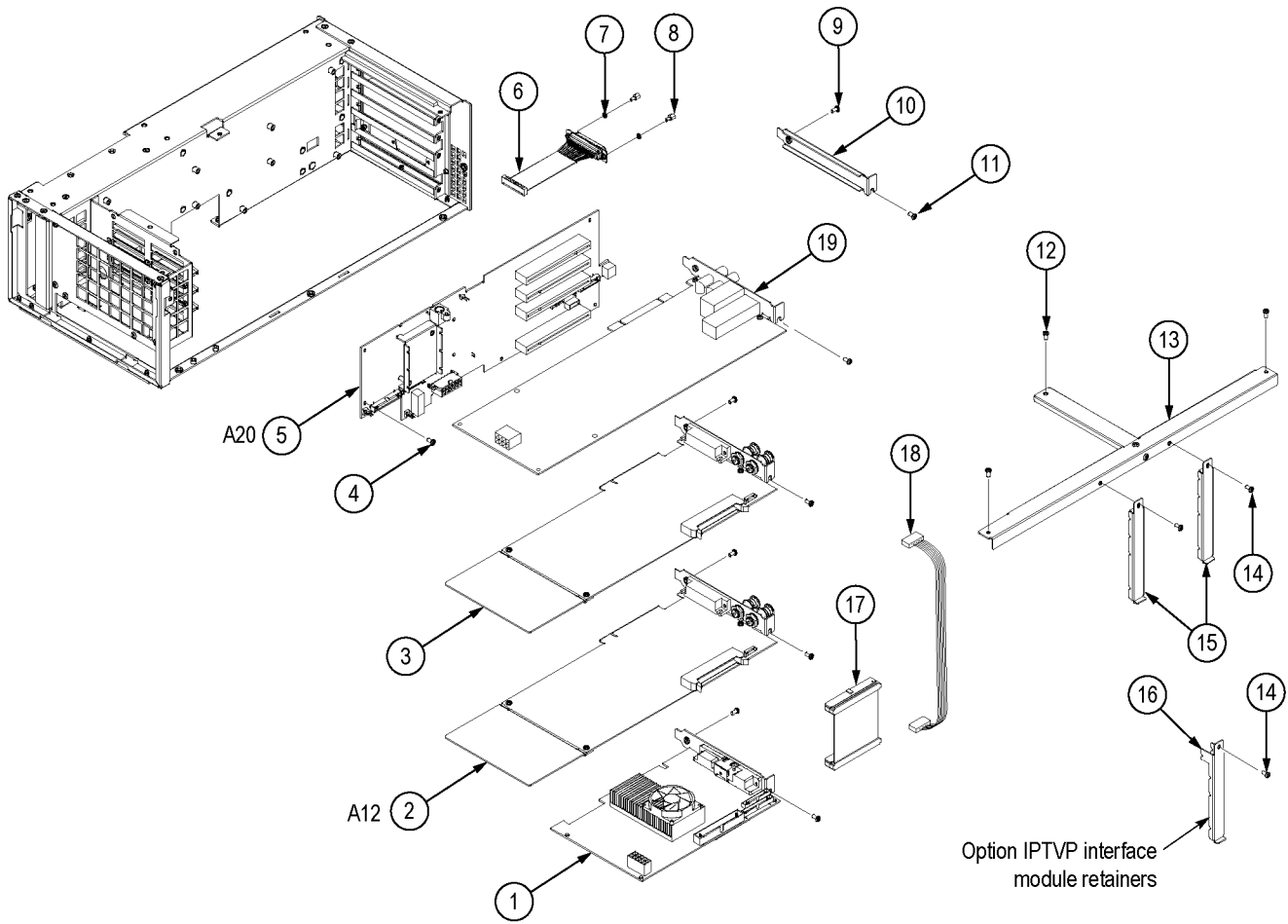

Figure 5-2: Internal modules

**Table 5-3: Replaceable parts list - Board modules**

Fig. & index number	Tektronix part number	Serial no. effective	Serial no. discont'd	Qty	Name & description
5-3					<b>Circuit Boards</b>
-1	650-4981-00			1	PROCESSOR MODULE W/BRACKET+LABEL 334A48100
-2	671-5975-00			1	CIRCUIT BD ASSY;A12,MAIN,389-3734-00 WIRED
-3	671-6118-00			1	CIRCUIT BD ASSY;A100 (OPTION 01)
	671-6119-00			1	CIRCUIT BD ASSY;A110 (OPTION 02)
	671-6120-00			1	CIRCUIT BD ASSY;A140 (OPTION 05)
	671-6141-00			1	CIRCUIT BD ASSY;A170 (OPTION 07)
-4	211-0373-00			10	SCREW,MACHINE:4-40X0.25,PNH,STL ZN-CM1,T10 TORX
-5	671-5976-00			1	CIRCUIT BD ASSY;A20,PCI BACK PANEL,389-3735-00 WIRED
-6	174-5190-00			1	CABLE ASSEMBLY,28AWG FLAT,1.27CTR,W/CONN D-SUB25&2X13
-7	210-0054-00			2	WASHER,LOCK:#4 SPLIT,0.025 THK STL CD PL
-8	214-3903-01			2	SCREW,JACK:4-40X0.312 EXT THD,4-40 INT THD,0.188 HEX,STEEL,CAD PLATE
-9	211-0373-00			4	SCREW,MACHINE:4-40X0.25,PNH,STL ZN-CM1,T10 TORX
-10	333-4518-00			1	PANEL,PCI:BLANK,NI PL,STL
-11	211-0373-00			4	SCREW,MACHINE:4-40X0.25,PNH,STL ZN-CM1,T10 TORX
-12	211-0373-00			3	SCREW,MACHINE:4-40X0.25,PNH,STL ZN-CM1,T10 TORX
-13	426-2624-00			1	FRAME,SECTION:TOP,MTX100A,STL
-14	211-0373-00			2	SCREW,MACHINE:4-40X0.25,PNH,STL ZN-CM1,T10 TORX
-15	343-1697-00			2	RETAINER:CKT BD,PCI,MTX100A,STL (STANDARD INSTRUMENTS)
-16	343-1729-xx			2	RETAINER:VIDEO-GBE BD, PCI, MTX100A, STL (OPTION IPTVP ONLY)
-17	174-B924-xx			1	CABLE ASSY, SP; 80, 30AWG, 5CM L, FLAT, W/CONN (OPTIONS 01, 02, 05, and 07 ONLY)
-18	174-5627-xx			1	CABLE ASSY;RS232 CIP,TRITON TO SBC; SAFETY CONTROLLED (OPTION IPTVP ONLY)
-19	671-6439-xx			1	CIRCUIT BD ASSEMBLY, TESTED;IPTV GIGABIT ETHERNET INTERFACE WITH 10/100/1000 BASE-T RJ45 ELECTRICAL PORT (OPTION IPTVP ONLY)





0191-010

Figure 5-3: Internal board modules

**Table 5-4: Front-panel unit**

Fig. & index number	Tektronix part number	Serial no. effective	Serial no. discont'd	Qty	Name & description
5-4					<b>Front Panel Unit</b>
-1	335-2098-00			1	MARKER,IDENT:LABEL,MTX100B,POLYCARBONATE,SAFETY CONTROLLED
-2	101-0175-00			1	TRIM;FRONT BEZEL,PC/ABS,TV GRAY,MTX100B,SAFETY CONTROLLED
-3	337-4389-00			1	SHIELD,DISPLAY;5.568 X 4.221,0.090 THICK,0.050 THICK GLASS,0.040 BLACK PORON W/0.002 THK ADHESIVE;MTX100B
-4	211-0373-00			4	SCREW,MACHINE:4-40X0.25,PNH,STL ZN-CM1,T10 TORX
-5	119-7205-00			1	DISPLAY MODULE;LCD,COLOR;1024X768 (XGA),6.3 DIAG,TFT,8/6-BIT LVDS,250 NIT BACK LIGHT,0.125 MM PIXEL PITCH,21MS,FRONT MOUNT,NL10276BC-02,SAFETY CONTROLLED
-6	407-5197-00			1	BRACKET;DISPLAY/FRONT PANEL,AL,MTX100B
-7	174-5266-00			1	CA ASSY;RIBBON ADAPTER TO XGA DISPLAY,20 PIN,3.5IN
-8	174-3767-01			1	CABLE ASSY,SP;DISCRETE,BACKLIGHT,IDC,26 AWG,5.0 L,PCB,1 X 6,0.079 CTR (2MM),SHRINK WRAPPED
-9	119-5999-00			1	POWER SUPPLY;INVERTER BOARD,REPLACEMENT FOR LCD 119-5659-00 6.5 LCD
-10	211-1117-00			2	SCREW,MACHINE:4-40 X 0.187,PAN HEAD,STL,CD PL,T-10,TORX DR
-11	335-0577-00			1	LABEL,MANUFACTURED;PRODUCT ID,2.5 IN X 1.5 IN,SAFETY CONTROLLED
-12	211-1117-00			4	SCREW,MACHINE:4-40 X 0.187,PAN HEAD,STL,CD PL,T-10,TORX DR
-13	679-6251-00			1	CIRCUIT BD ASSY,UNTESTED,389388900 WIRED;FRONT PANEL PROCESSOR, MTX100B
-14	337-4390-00			1	SHIELD ELEC;KEYPAD BOARD,0.020 THK POLYCARBONATE,LEXAN FR60,MTX100B, SAFETY CONTROLLED
-15	679-6250-00			1	CIRCUIT BD ASSY,UNTESTED,389388800 WIRED;KEYBOARD;L-SHAPE,MTX100B
-16	211-0373-00			2	SCREW,MACHINE:4-40X0.25,PNH,STL ZN-CM1,T10 TORX
-17	260-2834-00			1	SWITCH,KEYPAD;ELASTOMERIC FRONT PANEL MTX100B
-18	260-2835-00			1	SWITCH,ELASTOMERIC,POWER AND PLAY BUTTONS;FRONT PANEL MTX100B
-19	335-1595-00			1	LABEL,FRONT PANEL CONTROL,MTX100B

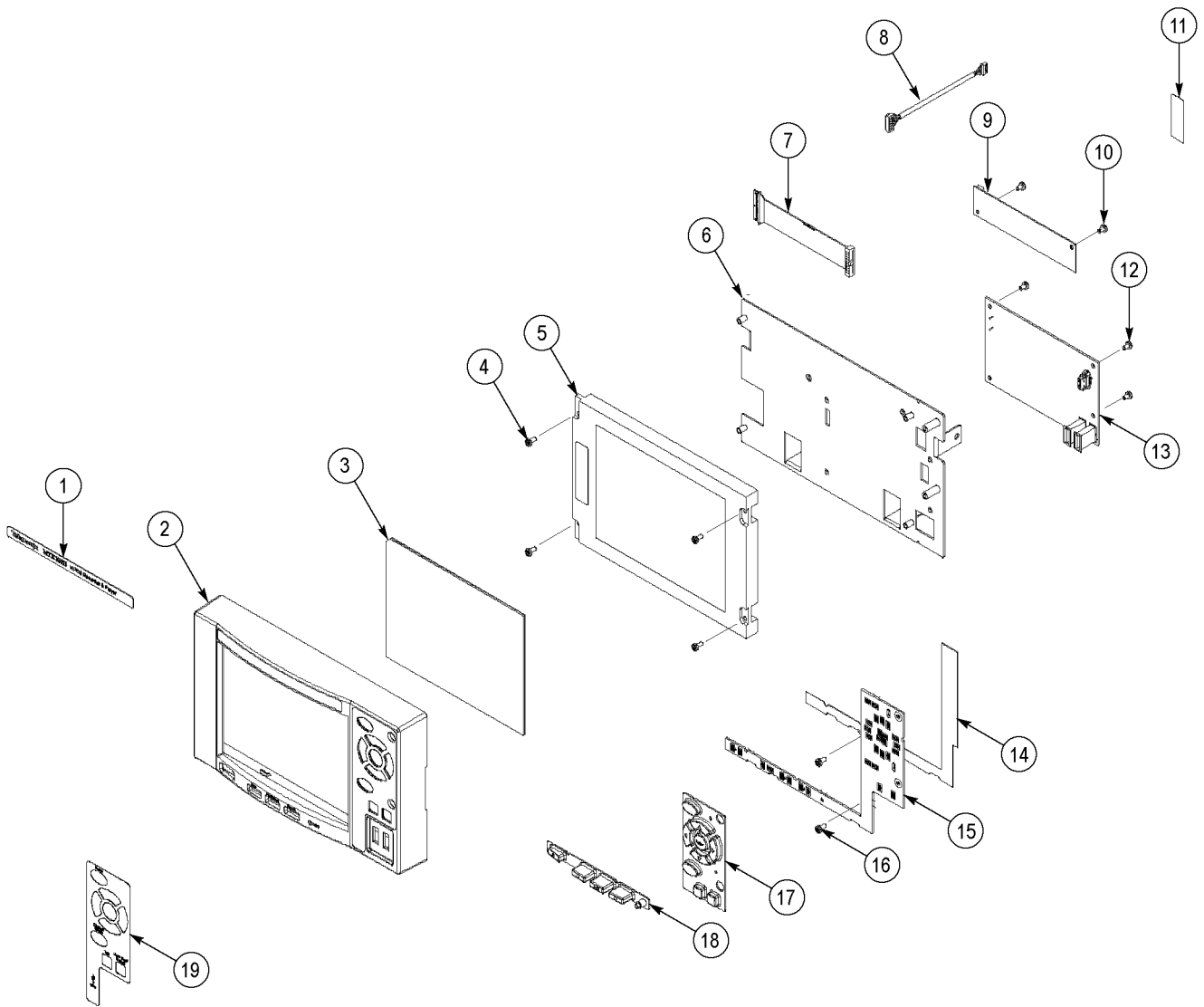

Figure 5-4: Front-panel unit

**Table 5-5: Replaceable parts list - Cables**

Fig. & index number	Tektronix part number	Serial no. effective	Serial no. discont'd	Qty	Name & description
5-5					<b>Cables</b>
-1	174-5183-00			1	CABLE,ASSEMBLY,2X20,FLAT,430MM L,ULTRA ATA (CPU-HDD,HDD IDE)
-2	174-5181-00			1	CABLE,ASSEMBLY,4,18AWG,60MML,HDD POWER (HDD-A20,POWER)
-3	174-5172-00			1	CABLE,ASSEMBLY,2,22AWG,50MM L,W/CONN 22-01-3027(MOLEX),( A20-A4-,5V STAND-BY)
-4	174-5177-00			1	CABLE,ASSEMBLY,7,18AWG,50MM I;VHR-10N&VHR-7N+XHP-2(JST), (P/S-A20,POWER&CONTROL)
-5	174-5178-00			1	CABLE,ASSEMBLY,6,18AWG,110MM L,W/CONN VHR-6N(JST),(P/S-A20,GND)
-6	174-5171-00			1	CABLE,ASSEMBLY,2,18AWG,130MM I,W/CONN VHR-5N(JST) (P/S-A40)
-7	174-5170-00			1	CABLE,ASSEMBLY,2,18AWG,40MM I,AC INLET to A40(INLET-A40)
-8	196-3449-00			1	LEAD,ELECTRICAL;18AWG,4.0 L,5-4 SAFETY CONTROLLED
-9	119-7186-00			1	CABLE,ASSEMBLY,SP,ELEC;FAN 119B05500 W/CABLE,10CM L (40 SQ FAN)
-10	174-B924-00			1	CABLE,ASSEMBLY,SP,ELEC:80,30AWG,5CM L,FLAT,W/CONN(YAMAICHI)
-11	174-5190-00			1	CABLE,ASSEMBLY,28AWG FLAT,1.27CTR,W/CONN D-SUB25&2X13(DSUB25-CPU)
-12	174-5186-00			1	CABLE,ASSEMBLY,2X10,28AWG FLAT,1MM CTR,130MM L,RS232C SLOT PC TO A20 (CPU-A20,RS2-232C)
-13	174-5348-00			1	CABLE,ASSEMBLY,2X5,28AWG FLAT,1MM CTR,120MM L,PANNEL SLOT PC TO A20 (CPU-A20,PANEL CONTROL)
-14	174-5184-00			1	CABLE,ASSEMBLY,14,30AWG 7TWISTED PAIRS,270MM L,LVDS SLOT PC TO A20, (CPU-A20,LCD LVDS)
-15	174-5174-00			1	CABLE,ASSEMBLY,12,18AWG,150MM L,SLOT PC POWER(CPU-A20,CPU POWER)
-16	119-7187-00			1	CABLE,ASSEMBLY,SP,ELEC;FAN 119569400 W/CABLE 18CM L (92 SQ FAN)
-17	174-5188-00			1	CABLE,ASSEMBLY,SP,ELEC;10,60CM L,26AWG AND 28 AWG(CPU-A35,USB)
-18	174-5220-00			1	CABLE,ASSEMBLY,2X15,28AWG FLAT,1MM CTR,300MM L,A20 TO A30
-19	174-3767-01			1	CABLE,ASSEMBLY,SP;DISCRETE,BACKLIGHT,IDC,26 AWG,5.0 L,PCB,1 X 6,0.079 CTR (2MM),SHRINK WRAPPED
-20	174-5266-00			1	CABLE,ASSEMBLY;RIBBON ADAPTER TO XGA DISPLAY,10 PIN,3.5IN

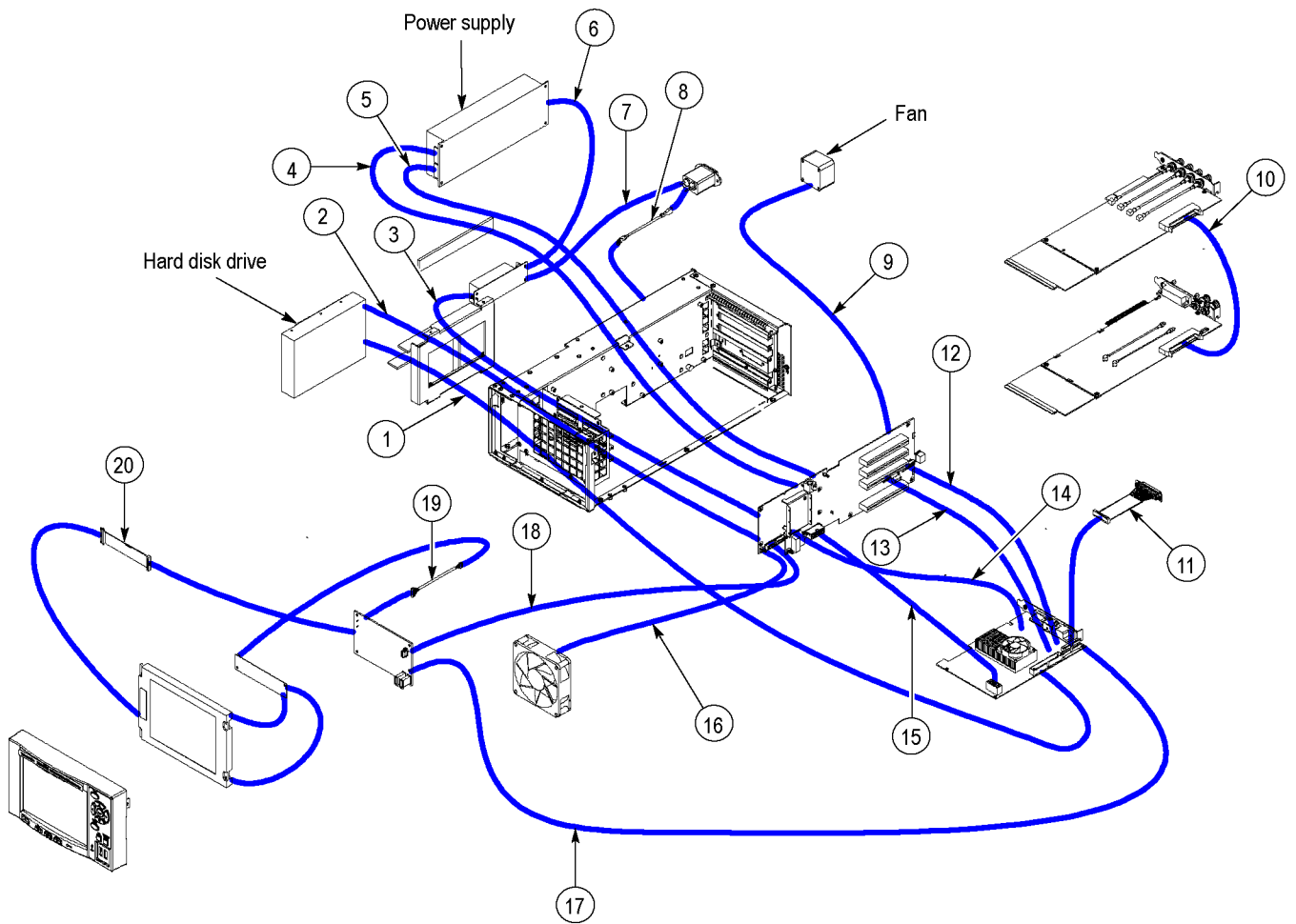

Figure 5-5: Cables

**Table 5-6: Accessories**

Tektronix part number	Serial no. effective	Serial no. discount'd	Qty	Name & description		
<b>Standard accessories</b>						
071-2610-XX			1	MANUAL,QSUM,MTS400P,ENGLISH (OPTION L0)		
071-2611-XX			1	MANUAL,QSUM,MTS400P,JAPANESE (OPTION L5)		
077-0204-00			1	MTS400 SERIES GENERATOR APPLICATIONS USER MANUAL		
063-3932-00			1	MTX100B/RTX100B/RTX130B SAMPLE STREAMS, CD,B019999 AND BELOW		
020-2941-00			1	MPEG TEST STREAMS DVD PACKAGING KIT, B020000 AND ABOVE		
012-A220-00			1	CABLE,INTCON:D-SUB 25,MALE TO MALE,STR,TWIST,2M L,SCREW 4-40		
119-6936-00			1	POINTER ASSY:OPTICAL MOUSE,USB,WHITE,OPTICAL THREE BUTTON WHEELED,W/USB to PS2 ADAPTER,ABS,SAFETY CONTROLLED		
119-B146-00			1	KEYBOARD:USB;MTX100,SAFETY CONTROLLED		
200-4716-00			1	COVER,FRONT;PROTECTIVE,PC/ABS FR110,W/TAPE;TV GRAY		
See Description			1	<b>Power Cords</b>		
				<b>Option</b>	<b>Country</b>	<b>Part Number</b>
				A0	North America	161-0066-00
				A1	Europe	161-0066-09
				A2	United Kingdom	161-0066-10
				A3	Australia	161-0066-13
				A4	North America, 240 V	161-0066-12
				A5	Switzerland	161-0154-00
				A6	Japan	161-0298-00
				A10	China	161-0304-00
				A11	India	161-0324-00
<b>Optional Accessories</b>						
077-0201-XX			1	MANUAL,TECH:SERVICE,MTS400P		
			1	WFM7F05 OPTION NN RACKMOUNT KIT		
			1	1700F06 BLANK PANEL		